



EQUINOX AERATING FOUNTAIN

- » Most energy efficient system in the industry.
- » 5 year all-inclusive warranty.
- » Operates in 30in or 75cm of water, an additional 10in or 26cm are required if adding lights.
- » Complete package includes assembled unit, power control center, and cable. (No PCC for 50HZ.)
- » Power control center comes standard with surge arrestor, timer and GFCI (Exc: optional EPD for 460V.)
- » Cable quick disconnect standard.
- » Safety tested and listed with ETL & ETL-C, conforming to UL standards; and carries a 3rd party listing with CE.
- » Effectively controls algae, aquatic weeds, and foul odors; while deterring insects and insect breeding.
- » Published results from 3rd party testing verify highest oxygen transfer and pumping rates in the industry.

Product specifications and CADs can be found online through www.otterbine.com or www.caddetails.com.



*We Guarantee that
You'll Love Your Pattern*

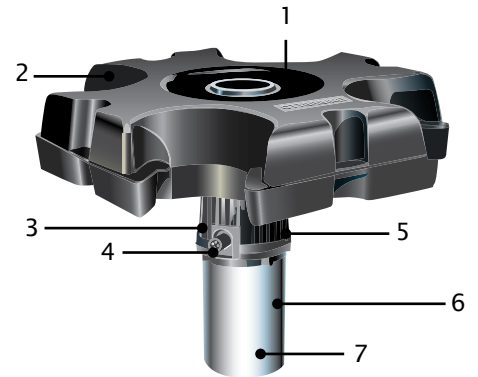

PRODUCT ILLUSTRATION

1. High-tech thermal plastic pumping chambers are staged to allow for easy interchange.
2. Rugged low visibility closed cell foam filled float includes handles and protective pockets for lights when applicable.
3. Industrial strength thermal plastic screen helps keep debris out of the unit.
4. Electrical quick disconnect is part of the upper plate to prevent damage.
5. Mixed flow pumping system achieves maximum pumping capacities.
6. Oil cooled, efficient 3450/2875 RPM custom built motor incorporates a silicon carbide single seal to ensure dependability and long life.
7. Corrosion resistant, durable 18 gauge/316 grade stainless steel motor housing.

60 HZ	1 HP	2 HP	3 HP	5 HP
Spray Height (ft)	10	13	15	20
Spray Diam. (ft)	35	40	58	72
GPM	150	210	275	400
Volt/Ph/Amp 3450@60hz	115/1/15 230/1/7.5	230/1/11.4	230/1/12 230/3/7.6 460/3/4.1	230/1/20 230/3/11.4 460/3/6