

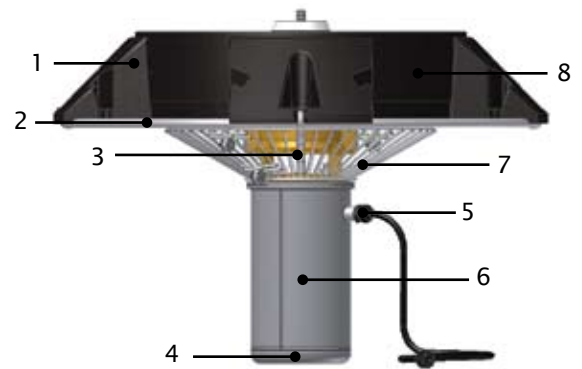

EQUINOX

LARGE AERATING FOUNTAIN

- » Most energy efficient system in the industry.
- » 2 year all-inclusive warranty.
- » Operates in 40in or 1m of water.
- » Air-filled wing floats allow for water intake to adjust float buoyancy and visibility in the water.
- » Complete package includes assembled unit, power control center, and cable. (No PCC for 50HZ.)
- » Power control center comes standard with surge arrestor, timer and GFCI (Exc: optional EPD for 460V.)
- » Cable quick disconnect standard.
- » Safety tested and listed with ETL, ETL-C, conforming to UL standards, and carries a 3rd party listing awith CE.
- » Effectively controls algae, aquatic weeds, and foul odors; while deterring insects and insect breeding.
- » Published results from 3rd party testing verifies highest oxygen transfer and pumping rates in the industry.



PRODUCT ILLUSTRATION

1. Unique float design includes 'wing floats' that allow for adjustments to float visibility.
 2. Stainless steel float ring for easy handling and maneuverability.
 3. Mixed flow pumping chamber achieves maximum pumping capacities.
 4. Corrosion resistant, durable 16 gauge/304 grade stainless steel motor housing, with oil plug located on bottom for ease of maintenance.
 5. Electrical quick disconnect is integrated into motor housing with extension cable for simplified maintenance.
 6. Oil cooled, efficient 3450/2875 RPM custom motor is sealed to ensure dependability and long life.
 7. Industrial strength, corrosion resistant stainless steel screen protects pump and motor from debris.
 8. Recessed pockets protect light fixtures when applicable.
- Minimum operating depth is 40in or 1m with and without lights. See www.otterbine.com for product testing and package details.

50 HZ	7.5 HP	10 HP
Spray Height (m)	5.2	7.3
Spray Diam. (m)	15.8	19.8
m ³ /hr	120.4	131.7
Volt/Ph/Amp 2875@50hz	400/3/13.5	400/3/18.5

Product specifications and CADs can be found online through www.otterbine.com or www.caddetails.com