



MYSTIC

GIANT FOUNTAIN

- » 2 year all-inclusive warranty, or 3 year warranty when purchased with power monitoring Subtrols.
- » Operates in 6ft or 2m of water.
- » Complete package includes assembled unit, power control center, and cable. (No PCC for 50Hz)
- » Power control center comes standard with surge arrester, timer and GFCI (Exc: optional EPD for 460V.)
- » Cable quick disconnect. (Optional)
- » Wheeled launching system ends the need for hoists and cranes in most applications.
- » Removable screen protects pump from debris, and is easy to clean from the water.
- » Safety tested and listed with ETL, and ETL-C.
- » Optional accessories include Fountain Glo™ 250W, 500W or 1000W light systems; wind controls, and power monitoring Subtrols.

| 50 HZ | 10 HP | 15 HP | 25 HP |
|--------------------------|----------|----------|----------|
| Spray Height (m) | 11.6 | 14.3 | 18.9 |
| Spray Diam. (m) | 1.8 | 1.8 | 1.8 |
| m ³ /hr | 102.2 | 113.5 | 181.6 |
| Volt/Ph/Amp 2875@50hz | 400/3/16 | 400/3/24 | 400/3/40 |

Product specifications and CADs can be found online through www.otterbine.com or www.caddetails.com.

www.otterbine.com/mystic



Manufactured by: Otterbine® Barebo, Inc. | 3840 Main Road East | Emmaus, PA 18049 U.S.A | PH: 610-965-6018 | Email: info@otterbine.com

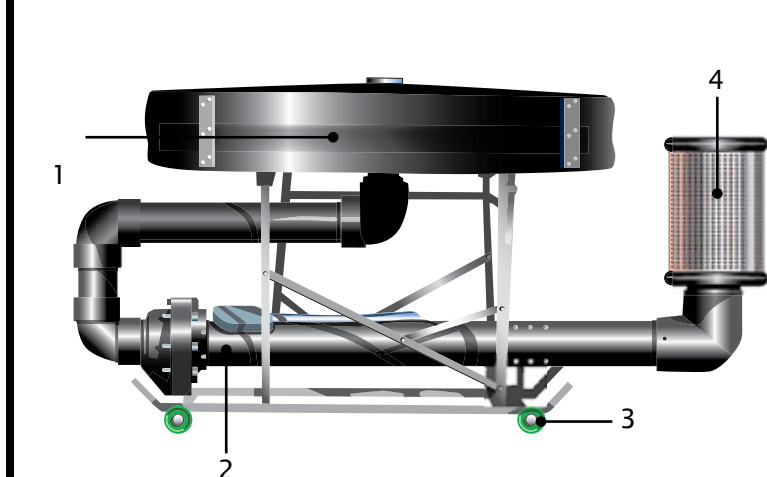

PRODUCT ILLUSTRATION

1. Special polyethylene float allows for easy height adjustment to make it less visible in the water.
2. High quality Grundfos pump and Franklin 3450/2875 RPM motor ensure years of corrosion-resistant, trouble-free run time and no maintenance.
3. Unique wheeled launching system eliminates the need for cranes during installation in most applications.
4. Removable stainless steel intake screen allows for cleaning in the water and protects pump from debris.

Complete package is safety tested, approved and listed with ETL and ETL-C. Minimum operating depth is 6ft or 2m, with and without lights. See www.otterbine.com for package details.