



**Owner's Manual  
Instant Fountain Water Feature**

**WHERE TO FIND IT:**

Water Feature Placement .....	3
Installation .....	3-10
Technical Specifications .....	10
Adjusting/Changing Spray Patterns and Accompanying Exploded View Diagrams .....	11-19
Trouble Shooting Guide .....	20-21
Maintenance .....	22
Winterization .....	22
Exploded View Diagram - Unit .....	23
Parts Order Form .....	24
Warranty .....	25

## I. Water Feature Placement

When using your Water Feature for aesthetic enhancement only, position the Water Feature in the place you feel it is best suited. When using your Water Feature for water aeration choose the Starburst pattern and place the Water Feature as shown below.

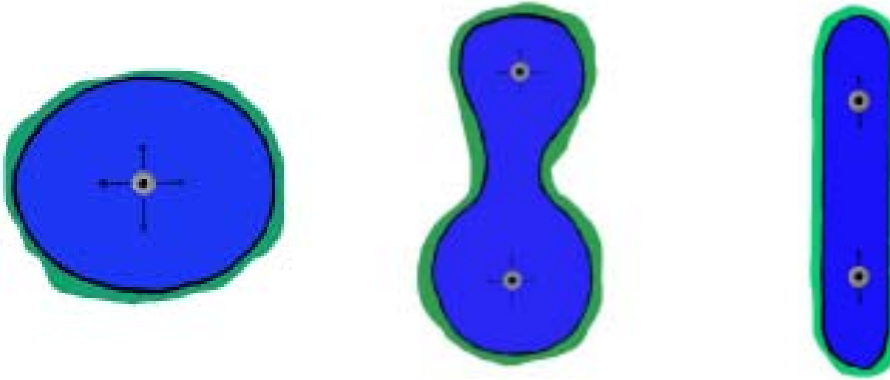

## II. Unit Installation

A. Unpack and inspect your Water Feature. Remove the protective cardboard ring around the top of the unit. Report any shipping damage to the carrier who delivered your Otterbine Water Feature. Verify you have received the following:

1. Water Feature - you will find a label located on the inner motor housing. This label can be read through the screen. Check to make sure you have received the correct horsepower and voltage. Also, verify you received the correct length of power cable with your Water Feature.
2. Power Control Center - A mini power control center is standard on all 60Hz Water Features. If your unit is 60Hz, verify the control center is present. On 50Hz units, the panel is optional. If ordered, verify the panel is of the proper voltage and frequency.
3. Hardware Kit - included in this kit are 2 mooring/anchor clips, a rocket spray nozzle, 2 cable ties and one 1/8" Allen wrench.
4. Warranty Registration Card - make sure to fill in your Otterbine warranty registration card and send it back to the factory.

**WARRANTY IS VOID UNLESS CARD IS RETURNED.**

5. Optional Light Kit - If lights were ordered, verify the proper number of lights and a light power control center are enclosed.

B. Prior to installation, please measure your water depth. All Otterbine Instant Fountain Water Features require at least 18" or .5m of water to run properly. If the water is too shallow, dig out a portion of the pond bottom directly under the Water Feature. If high waves or large fluctuations in depth occur, it will be necessary to allow for more than the required 18" or .5m.

C. Pattern Selection: your Otterbine Water Feature has been factory configured with the PHOENIX spray pattern. If the ROCKET or STARBURST pattern is desired, refer to the "ADJUSTING/CHANGING SPRAY PATTERN SECTION" of this manual and change the pattern at this time.

D. Light Kit: lights are optional on your Water Feature. If ordered with your unit, they should be installed on the Water Feature at this time. Electrical installation must be completed by a qualified licensed electrician. Refer to the LIGHT INSTALLATION section of this manual.

### III. Electrical Installation

**WARNING: TO PREVENT FATAL OR SERIOUS ELECTRICAL SHOCK, THIS EQUIPMENT MUST BE INSTALLED:**

- By a licensed electrician
- In compliance with national and local electrical codes
- With the proper size fusing and/or circuit breaker protection
- With 5 milliamp ground fault protection (GFCI)

A. Your Water Feature is safety tested and ETL, ETLc and CE listed. However, proper installation is the most crucial step to assure a safe and reliable unit.

B. Install Otterbine Power Control Panel as close to pond as possible. The enclosure is rated for both indoor and outdoor use. Mount panel a minimum of 3' (1m) above the ground and above any flood zone. Always keep the panel door closed.

## TYPICAL 115V CONTROL PANEL INSTALLATION

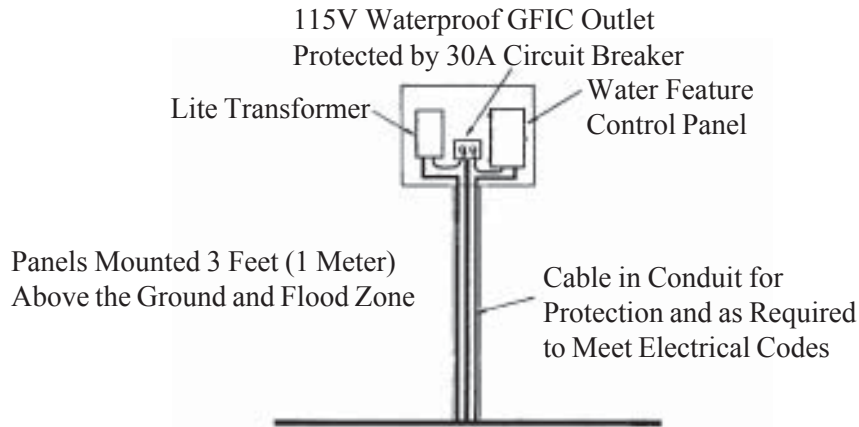

Verify your power cable does not exceed maximum recommended length. If additional length is required, contact Otterbine for a solution.

**CAUTION:** The power control panel must not be accessible from the water.

### Maximum Cable Length

Horsepower	Voltage	Frequency (Hz)	Maximum Length #12 Cable
1/2	115	60	125' or 37.8m
1/2	230	60	480' or 146.3m
1/2	220	50	700' or 213.4m
3/4	230	60	350' or 106.7m

C. Have a licensed, qualified electrician install the proper size fusing and/or circuit breaker protection as listed below. All work must be done in compliance with national and local electrical codes.

**NOTE:** THE 230V panel includes the proper fusing.

Horsepower	Voltage	Frequency (Hz)	Circuit Breaker Size	Slo-Blow/Delay Fuse Size
1/2	115	60	30	20
1/2	230	60	15	10
1/2	220	50	15	10
3/4	230	60	20	15

D. Have the electrician connect the power control center to the power source.

**NOTE:** For 115V units, a plug is supplied with the panel. This plug must be attached to the Water Feature cable and installed only into the power control panel

**WARNING:** Never run the Water Feature out of the water. Running the unit out of the water may damage the motor and void warranty.



**CAUTION: KEEP HANDS CLEAR OF THE IMPELLER WHEN TRYING TO START THE WATER FEATURE.**

E. Physically disconnect the power cable from its source and proceed with the installation of the unit.



#### **THERMALLY PROTECTED AUTOMATIC RESET**

- UNIT WILL RESTART WITHOUT WARNING AFTER PROTECTOR TRIPS.
- KEEP FINGERS OUT OF IMPELLER SYSTEM UNTIL UNIT IS DISCONNECTED.
- ALWAYS DISCONNECT UNIT FROM POWER SOURCE BEFORE SERVICING.

**NOTE:** This unit contains thermal protection to help prevent intense heat conditions in the motor that could damage the motor. If your unit is intermittently starting and stopping, the unit is showing symptoms of a larger problem and you should disconnect power from the unit and call your local service center.

### **IV. Physical Installation**

**NOTE:** Your Otterbine Water Feature may either be moored or anchored in the water. Mooring is the preferred method as it provides an easy method to retrieve the unit and allows for fluctuations in water height.

**WARNING:** DO NOT USE THE POWER CABLE AS A MOORING LINE.

A. The hardware kit supplied with your unit includes 2 mooring clips. These clips are designed to slide into any of the 6 slots in the bottom of the float cover.

B. Install two mooring clips on opposite sides of the unit. Fasten the clips from the inside so that the holes are on the outside. Refer to figure below.

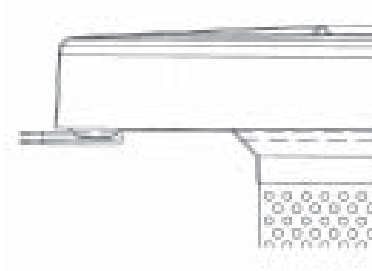

C. Using cable tie supplied, secure power cord to one of the cable tie mounts on the bottom of the unit.

D. Mooring the Water Feature

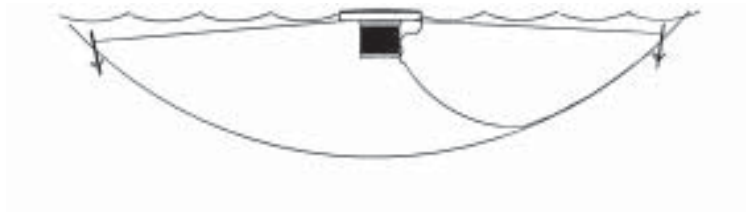

1. The following is required to moor your Otterbine Water Feature.
  - a. 1/4" or 6.3mm polypropylene rope or 1/8" stainless steel cable for use as mooring lines. Note: Use all brass or stainless steel hardware.
  - b. For mooring points, either wooden stakes, 1/2" or 125mm rebar, or "duckbill" type earth anchors.



-Duckbill Earth Anchors are driven into the ground, using a drive rod and heavy hammer, compacting the earth as they drive downward, until they reach the recommended depth. After removing drive rod, installer pulls up on cable. This planes or rotates the anchor into load lock position, like a toggle bolt in undisturbed earth.

2. Choose a suitable location for your water feature. Refer to the "WATER FEATURE PLACEMENT" section of this manual.
3. Secure your first mooring point. If you are using a stake or rebar, make sure to pound the mooring point securely into the ground on outer edge

of the pond. If you are mooring with an earth anchor, you will need to place the earth anchor two feet into the pond, below the surface of the water, and then pound the earth anchor two feet into the pond bottom. The earth anchor will allow your mooring lines to be virtually unnoticeable as it will be hidden beneath the water surface.

4. Attach the mooring lines to the mooring clips on the Water Feature.
5. Carefully, place the Water Feature into the water.
6. Walk one mooring line around to the far edge of the pond and pull the Water Feature into the desired location.
7. Secure your second mooring point. Attach the line/cable leaving enough slack in the lines to allow the Water Feature to turn 120 degrees or 1/3 turn. This slack will allow for proper start-up, wave action, and fluctuations in the water level.
8. Proceed to FINAL ELECTRICAL INSTALLATION instructions in this manual.

#### E. Anchoring the Water Feature

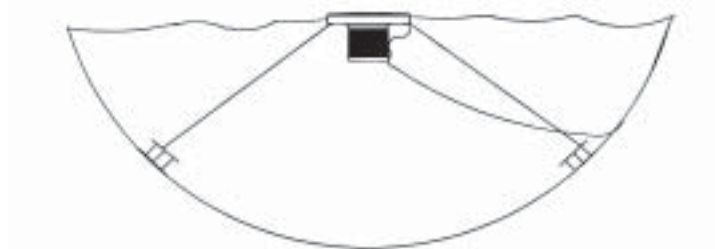

1. The following is required to anchor your Otterbine Water Feature.
  - a. 1/4" or 6.3mm polypropylene rope or 1/8" stainless steel cable for use as anchor lines. **Note:** use all brass or stainless steel hardware.
  - b. Two 15 lb or 8 kg anchors.

2. Choose a suitable location for your Water Feature. Refer to the “WATER FEATURE PLACEMENT” section of this manual.
3. Using a boat, take the Water Feature and anchors to the chosen location.
4. Drop the anchors (with anchor lines attached) out of the boat at a minimum of a 45 degree angle from the desired location of the Water Feature. See figure on previous page.
5. Bring the anchor lines together and secure each of them to the corresponding anchor clip on the Water Feature. Attach the line/cable leaving enough slack in the lines to allow the Water Feature to turn 120 degrees or 1/3 turn. This slack will allow for proper startup, wave action, and fluctuations in the water level.

## V. Final Electrical Installation

**CAUTION:** All electrical work must be done by a qualified, licensed electrician.

A. With the Water Feature securely moored or anchored, re-attach the power cable to the source of electricity.

**NOTE:** Otterbine suggests that the power cable be encased in conduit when placed underground. The Water Feature’s underwater power cable should be encased in conduit from the power source to approximately 3-4' or 1m out into the water. This insures against possible cable damage.

B. Apply power to the unit. With the unit running, have the licensed electrician conduct a voltage and amperage reading. Verify your unit is receiving the proper voltage. Record the voltage and amperage readings on the back cover of this manual.

C. Test the GFCI device for proper operation by depressing the test button. GFCI devices must be tested monthly or per manufacturers recommendations.

D. This completes the installation of your Water Feature. If desired, the spray pattern can be adjusted or changed. Refer to the ADJUSTING/CHANGING SPRAY PATTERN section of this manual.

## VI. Technical Specifications

Model	HP	Voltage and Phase	Motor RPM	Running Amp Draw	Spray Height*		Spray Diameter*		Pumping Rate
<b>Starburst</b>									
50	1/2	115 1 ph.	3450 @ 60Hz	12.0	2.5'		12'		125 gpm
		230 1 ph.	3450 @ 60Hz	6.0	2.5'		12'		125 gpm
75		220 1 ph	2875 @ 50Hz	3.9	0.8m		4.3m		24m <sup>3</sup> /hr
	3/4	230 1 ph.	3450 @ 60Hz	8.0	3.0'		19'		135 gpm
<b>Phoenix</b>									
					Inside	Outside	Inside	Outside	
50	1/2	115 1 ph.	3450 @ 60Hz	12.0	8'	4'	2'	12'	80 gpm
		230 1 ph.	3450 @ 60Hz	6.0	8'	4'	2'	12'	80 gpm
75		220 1 ph	2875 @ 50Hz	3.9	2.1m	1.2m	0.6m	3.7m	18m <sup>3</sup> /hr
	3/4	230 1 ph.	3450 @ 60Hz	8.0	9'	6'	2'	16'	90 gpm
<b>Rocket</b>									
50	1/2	115 1 ph.	3450 @ 60Hz	12.0	12'		2'		80 gpm
		230 1 ph.	3450 @ 60Hz	6.0	12'		2'		80 gpm
75		220 1 ph	2875 @ 50Hz	3.9	2.9m		0.6m		18m <sup>3</sup> /hr
	3/4	230 1 ph.	3450 @ 60Hz	8.0	15'		2'		90 gpm

\*Spray patterns will vary by adjusting the diffuser ring. Therefore, the figures given are averages. Spray patterns will also vary due to voltage drop, humidity and other relevant site situations

**Unit Weight:** 45 lbs. or 21K and includes power center, unit, spray patterns and 100' or 30.48m of underwater cable.

**Induced Circulation:** is 10 times the pumping rate. Induced circulation is the mixing effect which is occurring below the water's surface.

**Minimum Operating Depth:** is 18" or 500mm.

## VII. Adjusting and Changing Spray Patterns

Your Water Feature can be configured into three different spray patterns. It has been factory assembled with the Phoenix pattern. To change or adjust the pattern, refer to the proper section below and follow the directions carefully. Refer to the Exploded View Diagrams following each section for an illustration of referenced parts.

**A. Adjusting the Phoenix spray pattern.** The outer spray pattern of the Phoenix can be adjusted, using the supplied 1/8" Allen wrench, by repositioning the diffuser on top of the unit. Follow the steps below for adjustment.

1. Physically disconnect the power from the Water Feature.
2. Bring the Water Feature to shore and place the unit on a flat surface.
3. Using the supplied 1/8" Allen wrench, loosen the two setscrews holding the diffuser ring in position. Adjusting the ring up will lower the height of the outer pattern and increase its width. Lowering the ring will make the outer pattern higher and narrower. Adjust the ring to the new location and secure the two setscrews.

**NOTE:** CAREFULLY, SECURE THE SETSCREWS. APPLYING EXCESSIVE FORCE WILL DAMAGE THE RING OR NOZZLE ASSEMBLY. THE TOP OF THE RING MUST NOT BE ADJUSTED ABOVE THE TOP OF THE NOZZLE.

4. Place your unit back into the water, secure the mooring lines and re-apply power. If the pattern is not as desired, repeat above steps.

**B. Changing to the Phoenix spray pattern.**

1. Physically disconnect the power from the Water Feature.
2. Bring the Water Feature to shore and place the unit on a flat surface.
3. Using the supplied 1/8" Allen wrench, loosen the two setscrews securing the diffuser ring in position and remove the diffuser ring.

4. Remove the four 1/4" bolts and the four screws on the top of the top retainer.
5. Carefully lift the top retainer off of the unit. A slight twisting motion may be required.
6. If the unit was configured as a ROCKET, remove the Rocket nozzle from the unit.
7. Install the baffle into the top of the collector as illustrated below.

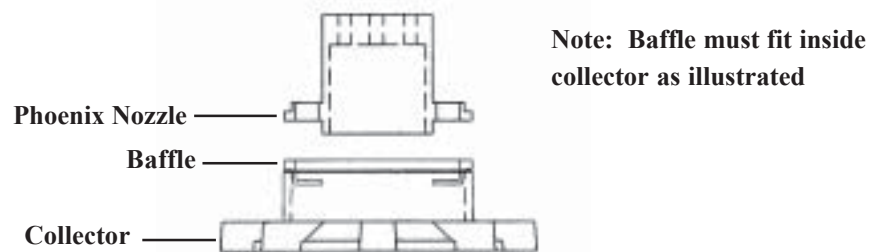

8. Place the Phoenix nozzle (nozzle with 8 holes in center area) into the retainer.
9. Place the retainer back on the unit, secure the retainer to the collector using the four 1/4" bolts.

**WARNING: DO NOT USE EXCESSIVE FORCE. DAMAGE TO THE PUMPING COMPONENTS MAY RESULT. MAXIMUM TORQUE IS 20 IN-LBS.**

10. Re-attach the retainer to the float using the four screws removed in step 4.

11. Re-attach diffuser ring.

**ALWAYS ATTACH DIFFUSER RING AS SHOWN,  
WITH ANGLED SIDE DOWN, HOLLOW SIDE UP.**

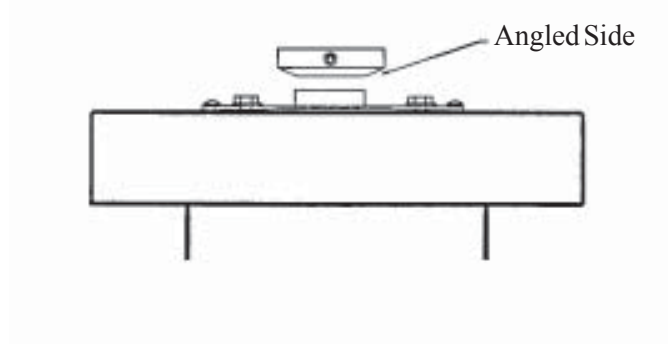

**NOTE:** CAREFULLY, SECURE THE SETSCREWS. APPLYING EXCESSIVE FORCE WILL DAMAGE THE RING OR NOZZLE ASSEMBLY. THE TOP OF THE RING MUST NOT BE ADJUSTED ABOVE THE TOP OF THE NOZZLE.

12. Place your unit back into the water, secure the mooring lines and re-apply power. If the pattern is not as desired, refer to adjusting PHOENIX SPRAY PATTERN SECTION.

## Exploded View Diagram Phoenix Pumping Configuration

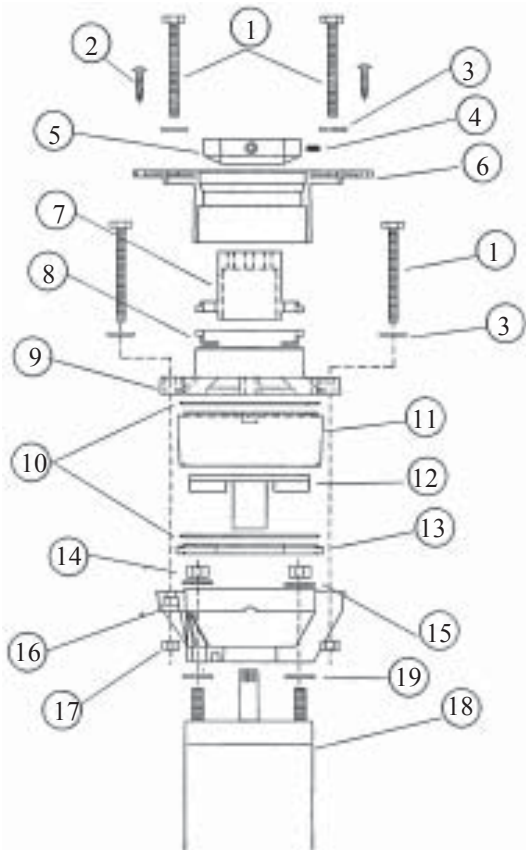

Item	P/N	Qty	Description
1	FR103	8	Hex Bolt, 1/4"-20 x 2.75"
2	FR109	11	Self Tapping Screw, #10
3	FR105	8	Flat Washer, 1/4"
4	FR108	2	Set Screw
5	FR804	1	Diffuser
6	FR209	1	Top Retainer
7	FR803	1	Phoenix Nozzle
8	FR805	1	Phoenix Baffle
9	FR207	1	Collector
10	FR701	2	O-Ring
11	FR206	1	Pump Chamber
12A	FR800	*	Impeller, 1/2HP 60Hz
12B	FR801	*	Impeller, 3/4HP 60Hz or 1/2HP 50Hz
13	FR205	1	Impeller Ring
14	FR102	4	Lock Nut, 5/16"-24
15	FR104	4	Flat Washer, 5/16"
16	FR204	1	Standoff
17	C2-112	4	Lock Nut, 1/4"-20
18A	FR601	*	Motor, 1/2HP 115V 60Hz
18B	FR602	*	Motor, 1/2HP 230V 60Hz
18C	FR603	*	Motor, 1/2HP 220V 50Hz
18D	FR604	*	Motor, 3/4HP 230V 60Hz
19	FR114	4	Heavy Washer, 5/16"

\* One per unit depending on horsepower, voltage, and frequency

### **C. Adjusting the Rocket spray pattern.**

The spray pattern of the ROCKET can be adjusted, using the supplied 1/8" Allen wrench, by repositioning the diffuser on top of the unit. Follow the steps below:

1. Physically disconnect the power from the Water Feature.
2. Bring the Water Feature to shore and place the unit on a flat surface.
3. Using the supplied 1/8" Allen wrench, loosen the two setscrews holding the diffuser ring in position. Adjusting the ring up will increase the spray pattern width and slightly lower it's height. Lowering the ring will make the pattern higher and narrower. Adjust the ring to the new location and secure the two setscrews.

**NOTE:** CAREFULLY, SECURE THE SETSCREWS. APPLYING EXCESSIVE FORCE WILL DAMAGE THE RING OR NOZZLE ASSEMBLY. THE TOP OF THE RING MUST NOT BE ADJUSTED ABOVE THE TOP OF THE NOZZLE

4. Place your unit back into the water, secure the mooring lines and re-apply power. If the pattern is not as desired, repeat above steps.

### **D. Changing to the Rocket spray pattern.**

1. Physically disconnect the power from the Water Feature.
2. Bring the Water Feature to shore and place the unit on a flat surface.
3. Using the supplied 1/8" Allen wrench, loosen the two setscrews securing the diffuser ring in position and remove the diffuser ring.
4. Remove the four 1/4" bolts and the four screws on the top of the top retainer.
5. Carefully lift the top retainer off of the unit. A slight twisting motion may be required.

6. If the unit was configured as a PHOENIX, remove the PHOENIX nozzle and baffle from the unit.
7. Place the ROCKET nozzle (nozzle without holes in center area) into the retainer.
8. Place the retainer back on the unit, secure the retainer to the collector using the four 1/4" bolts.

**WARNING: DO NOT USE EXCESSIVE FORCE.  
DAMAGE TO THE PUMPING COMPONENTS MAY RESULT.  
MAXIMUM TORQUE IS 20 IN-LBS.**

9. Re-attach the retainer to the float using the 4 screws removed in step 4.
10. Re-attach diffuser ring.

**ALWAYS ATTACH DIFFUSER RING AS SHOWN,  
WITH ANGLED SIDE DOWN, HOLLOW SIDE UP.**

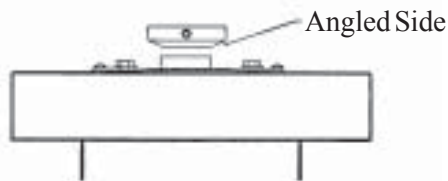

**NOTE:** CAREFULLY, SECURE THE SETSCREWS. APPLYING EXCESSIVE FORCE WILL DAMAGE THE RING OR NOZZLE ASSEMBLY. THE TOP OF THE RING MUST NOT BE ADJUSTED ABOVE THE TOP OF THE NOZZLE.

11. Place your unit back into the water, secure the mooring lines and re-apply power. If the pattern is not as desired, refer to ADJUSTING ROCKET SPRAY PATTERN SECTION.

## Exploded View Diagram Rocket Pumping Configuration

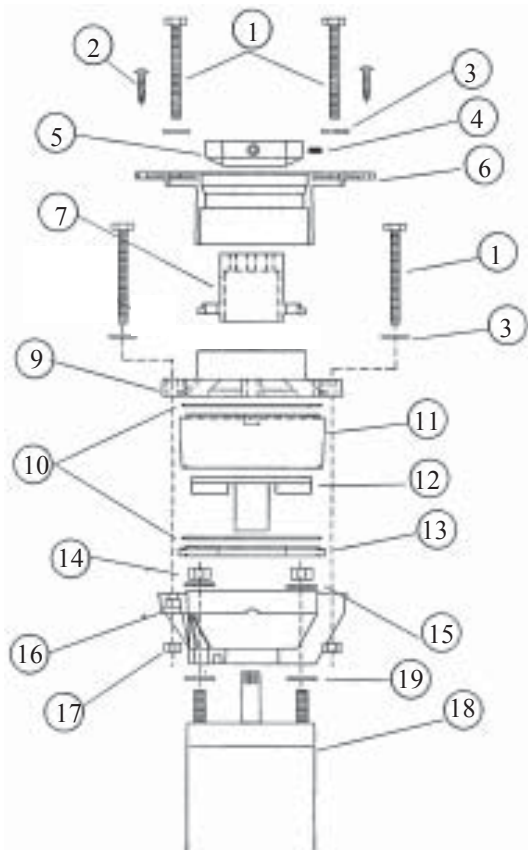

Item	P/N	Qty	Description
1	FR103	8	Hex Bolt, 1/4"-20 x 2.75"
2	FR109	11	Self Tapping Screw, #10
3	FR105	8	Flat Washer, 1/4"
4	FR108	2	Set Screw
5	FR804	1	Diffuser
6	FR209	1	Top Retainer
7	FR802	1	Rocket Nozzle
9	FR207	1	Collector
10	FR701	1	O-Ring
11	FR206	2	Pump Chamber
12A	FR800	1	Impeller, 1/2HP 60Hz
12B	FR801	*	Impeller, 3/4HP 60Hz or 1/2HP 50Hz
13	FR205	1	Impeller Ring
14	FR102	1	Lock Nut, 5/16"-24
15	FR104	4	Flat Washer, 5/16"
16	FR204	4	Standoff
17	C2-112	1	Lock Nut, 1/4"-20
18A	FR601	4	Motor, 1/2HP 115V 60Hz
18B	FR602	*	Motor, 1/2HP 230V 60Hz
18C	FR603	*	Motor, 1/2HP 220V 50Hz
18D	FR604	*	Motor, 3/4HP 230V 60Hz
19	FR114	*	Heavy Washer, 5/16"
		4	

\* One per unit depending on horsepower, voltage, and frequency

## E. Changing to the Starburst pattern.

**NOTE:** The shape of the Starburst pattern can not be adjusted.

1. Physically disconnect the power from the Water Feature.
2. Bring the Water Feature to shore and place the unit on a flat surface.
3. Using the supplied 1/8" Allen wrench, loosen the two setscrews securing the diffuser ring in position and remove the diffuser ring.
4. Remove the four 1/4" bolts and the four screws on the top of the top retainer.
5. Carefully lift the top retainer off of the unit. A slight twisting motion may be required.
6. Remove the nozzle from the unit. If the unit was configured as a PHOENIX, also remove the PHOENIX baffle.
7. Place the retainer back on the unit, secure the retainer to the collector using the four 1/4" bolts.

**WARNING: DO NOT USE EXCESSIVE FORCE.  
DAMAGE TO THE PUMPING COMPONENTS MAY RESULT.  
MAXIMUM TORQUE IS 20 IN-LBS.**

8. Re-attach the retainer to the float using the (4) screws removed in step 4.
9. Place your unit back into the water, secure the mooring lines and re-apply power. The Starburst pattern can not be adjusted.

## Exploded View Diagram Starburst Pumping Configuration

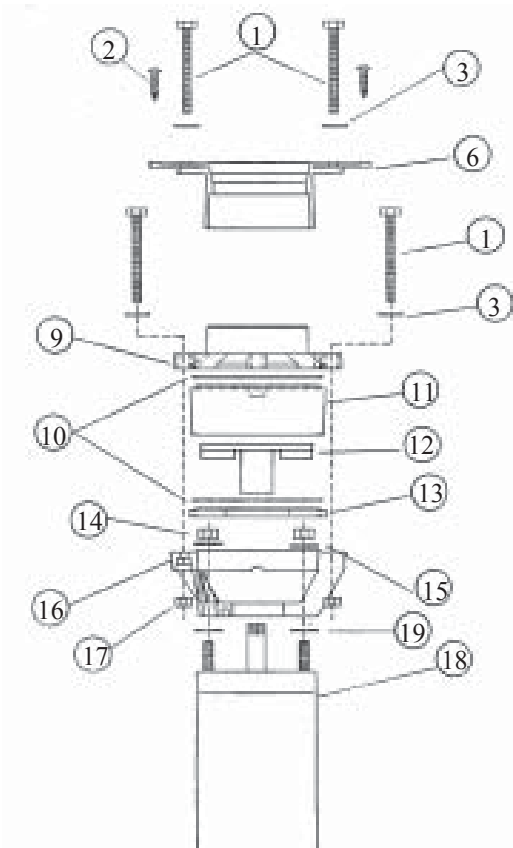

Item	P/N	Qty	Description
1	FR103	8	Hex Bolt, 1/4"-20 x 2.75"
2	FR109	11	Self Tapping Screw, #10
3	FR105	8	Flat Washer, 1/4"
6	FR209	1	Top Retainer
9	FR207	1	Collector
10	FR701	2	O-Ring
11	FR206	1	Pump Chamber
12A	FR800	*	Impeller, 1/2HP 60Hz
12B	FR801	*	Impeller, 3/4HP 60Hz or 1/2HP 50Hz
13	FR205	1	Impeller Ring
14	FR102	4	Lock Nut, 5/16"-24
15	FR104	4	Flat Washer, 5/16"
16	FR204	1	Standoff
17	C2-112	4	Lock Nut, 1/4"-20
18A	FR601	*	Motor, 1/2HP 115V 60Hz
18B	FR602	*	Motor, 1/2HP 230V 60Hz
18C	FR603	*	Motor, 1/2HP 220V 50Hz
18D	FR604	*	Motor, 3/4HP 230V 60Hz
19	FR114	4	Heavy Washer, 5/16"

\* One per unit depending on horsepower, voltage, and frequency

## VIII. Trouble Shooting Guide

SYMPTOM	POSSIBLE CAUSE	CORRECTION
Motor will not start	Breaker/fuse has tripped	Check breaker or fuse. Reset/replace
	Low voltage	Verify voltage in spec
	Excessive cable length	Verify acceptable maximum cable length
	Defective or disconnected power cable	Check & verify cable is properly connected
	GFCI device has tripped	Reset and test GFCI device. Replace if necessary
GFCI device trips continuously	Defective power cable	Inspect cable for torn insulation
	Bad or noisy power	Low voltage or surges may cause nuisance tripping
Unit turns on and off	Low voltage	Verify voltage is within spec
Fuse blows or circuit breaker trips	Excessive cable length	Verify acceptable maximum cable length
	Defective motor	Take a winding resistance reading 1/2HP 115V 60Hz = 1.0-1.3 ohms 1/2HP 220V 50Hz = 6.3-7.7 ohms 1/2HP 230V 60Hz = 4.2-5.2 ohms 3/4HP 230V 60Hz = 3.0-3.6 ohms

(Trouble Shooting Continued)

<b>SYMPTOM</b>	<b>POSSIBLE CAUSE</b>	<b>CORRECTION</b>
Spray pattern low or distorted	Clogged screen	Clean screen
	Clogged nozzle or pumping chamber	Clean nozzle or pumping chamber of debris
	Phoenix model, baffle is missing	Insert baffle in unit
	Rocket or Starburst model, baffle is present	Remove baffle
	Unit hitting bottom	Move unit to deeper water
	Diffuser ring installed wrong	Install diffuser ring with angled side down into unit
Rocket/Phoenix Spray pattern is straight up, low, and heavy	Missing diffuser ring	Attach diffuser ring
Phoenix model no inner spray pattern	Rocket nozzle installed	Install Phoenix nozzle (8 holes in center of nozzle)
Spray pattern tilted	Cables not attached to bottom of unit	Attach cable using cable tie

## **IX. Maintenance**

**Your Otterbine Water Feature has been designed for years of dependable service.**

- The screen should be cleaned as required to prevent any intake restrictions.
- At least once a year, you should thoroughly inspect the water feature, underwater cable, and mooring/anchor lines for any signs of external damage.

### **Winterization**

If the temperature in your region of the country falls below 30 degrees for any extended period of time, Otterbine strongly suggests that you remove your Water Feature from the water and store it in a dry and above freezing temperature location. Storage in a shed or garage where temperatures drop below freezing is not recommended as unit may freeze.

#### **!! WARNING !!**

**This unit is not made to run in winter weather conditions. Leaving your Otterbine Water Feature operating during the winter can lead to the Water Feature freezing in. If your Water Feature freezes in, motor or pumping component damage can occur. This will not be covered under warranty.**

**The motor used in this Water Feature is of a water lubricated design. Therefore, the unit must not be allowed to freeze as this will cause damage to the motor and pumping components. Unit must be stored in above freezing temperatures!**

## Exploded View Diagram Unit

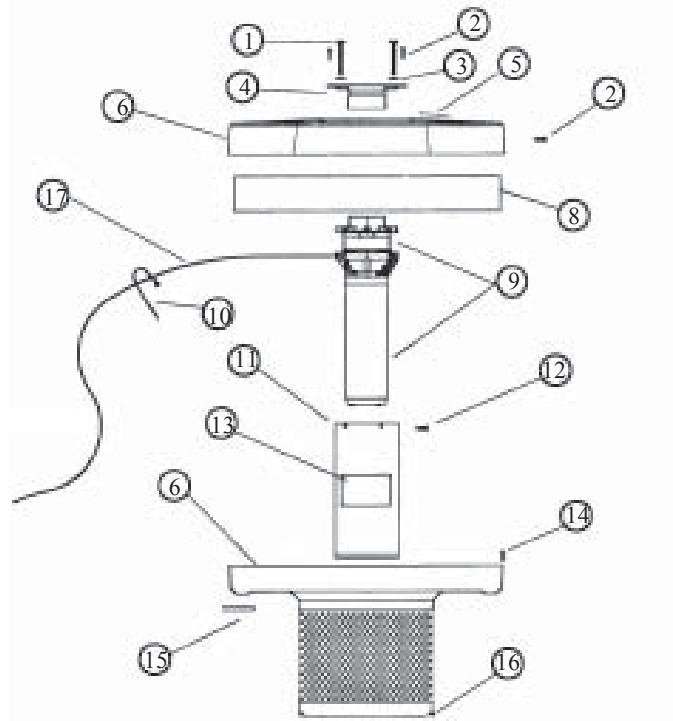

Item	P/N	Qty	Description
1	FR103	8	Hex Bolt, 1/4"-20 x 2.75"
2	FR109	11	Self Tapping Screw, #10
3	FR105	8	Flat Washer, 1/4"
4	FR209	1	Top Retainer
5	FR901	1	Warning Label
6	FR200	1	Shell/Screen Assembly
8	42-0011	1	Float
9		1	Pump Chmbr/Motor Assy
10	FR113	1	Cable Tie
11	FR301	1	Motor Sleeve
12	FR106	5	Self Tapping Screw, #8
13	C2-930	1	ID Label
14	FR101	11	Speed "U" Nut
15	FR302	2	Mooring Clip
16	FR112	2	Cable Tie Mount
17	FR500	1	Cord Assembly

**PARTS ORDER FORM**

NAME \_\_\_\_\_

ADDRESS \_\_\_\_\_

CITY \_\_\_\_\_ STATE \_\_\_\_\_ ZIP \_\_\_\_\_

DATE UNIT WAS PURCHASED \_\_\_\_\_

PURCHASED FROM \_\_\_\_\_

UNIT SERIAL NUMBER \_\_\_\_\_

QTY	PART NUMBER	DESCRIPTION
_____	_____	_____
_____	_____	_____
_____	_____	_____
_____	_____	_____
_____	_____	_____
_____	_____	_____
_____	_____	_____
_____	_____	_____
_____	_____	_____
_____	_____	_____

For price and availability, please call or write us at:  
OTTERBINE BAREBO, INC.  
3840 Main Road East  
Emmaus, PA 18049 USA  
(610) 965-6018 or (800) 237-8837  
[www.otterbine.com](http://www.otterbine.com)

**Limited 2 Year Warranty on Unit  
Limited 1 Year Warranty on Lights  
Otterbine® Product**

**WARRANTY:** Barebo, Inc 3840 Main Road East, Emmaus Pennsylvania 18049,U.S.A. hereby warrants, subject to the conditions hereinbelow set forth, that should the **OTTERBINE** product prove defective by reason of improper workmanship or materials at any time during the warranty period the Purchaser at retail will be guaranteed that **BAREBO** will repair or replace the said **OTTERBINE** product as may be necessary to restore it to satisfactory operating condition, without any charge for materials or labor necessarily incident to such repair or replacement, provided that:

- a) The enclosed Warranty Registration Card should be mailed to **BAREBO** within fifteen (15) days of the original receipt by the Purchaser at retail in order to avoid delays;
- b) The **OTTERBINE** product must be delivered or shipped, prepaid, in its original container or a container offering an equal degree of protection, to **BAREBO** or a facility authorized by **BAREBO** to render the said repair or replacement services or, if purchased from an authorized **OTTERBINE** dealer, to such dealer;
- c) The **OTTERBINE** product must not have been altered, repaired or serviced by anyone other than **BAREBO**, a service facility authorized by **BAREBO** to render such service, or by an authorized **BAREBO** dealer, and the serial number of the **OTTERBINE** product must not have been removed or altered; and
- d) The **OTTERBINE** product must not have been subjected to lightning strikes and other Acts of God, vandalism, freezing-in, accident, misuse or abuse, and must have been installed in conformance with applicable electrical codes (including proper electrical protection), and also installed, operated and maintained in accordance with guidelines in the Owner's Manual shipped with the Otterbine product.

No implied warranties of any kind are made by **BAREBO** in connection with this **OTTERBINE** product, and no other warranties, whether expressed or implied, including implied warranties of merchantability and fitness for a particular purpose, shall apply to this **OTTERBINE** product. Should this **OTTERBINE** product prove defective in workmanship or material, the retail Purchaser's sole remedy shall be repair or replacement as is hereinabove expressly provided and, under no circumstances, shall **BAREBO** be liable for any loss, damage or injury, direct or consequential, arising out of the use of, or inability to use, the **OTTERBINE** product, including but not limited to retail Purchaser's cost, loss of profits, goodwill, damages due to loss of product or interruption of service, or personal injuries to Purchaser or any person.

HORSEPOWER:            1/2 HP                    3/4 HP

VOLTAGE:                115V 60 Hz            220V 50Hz            230V 60Hz

CORD LENGTH:        100'                    OTHER \_\_\_\_\_

SERIAL NUMBER: \_\_\_\_\_

RUNNING VOLTAGE: \_\_\_\_\_ AMPERAGE: \_\_\_\_\_

WATER WORKS WITH OTTERBINE®!



Otterbine Barebo, Inc.  
3840 Main Road East  
Emmaus, PA 18049 U.S.A.  
[www.otterbine.com](http://www.otterbine.com)  
PH# 610-965-6018 or 800-AER8TER  
FAX # 610-965-6050