



# **Water Works With Otterbine**

## **TRITON<sub>2</sub> Owner's Manual**

A Guide to More Dependable  
Water Quality Management  
With Barebo Incorporated's  
Subsurface Aspirating Aeration Systems

**Welcome Aboard!**

Welcome to the growing family of people who depend on aerators for better water quality control and aesthetic improvement. All Otterbine products are safety tested and approved by ETL, ETL-C and CE

**Water Quality Specialists**

Barebo, Inc. is a team of scientists, engineers, and crafts persons who specialize in efforts to improve water quality. Otterbine aerators are built at Barebo, Inc.'s 25,000 square foot factory in Emmaus, Pennsylvania. Each step in assembly is followed by a quality assurance check to maintain high quality.

Otterbine aerators, made of stainless steel and high tech engineering plastics, reflects the results of aerator research and development programs that started in 1956, plus the experience gained through thousands of installations on commercial fish farms, golf courses, parks, and architectural applications.

**Follow the Guidelines**

You'll find guidelines for installing, operating, and maintaining your aerator in the following pages. We strongly recommend that you read, understand, and apply these guidelines. They will help you get better performance and dependability from your Otterbine aerator.



***SUB-TRITON<sub>2</sub>***



***AIRFLO***



***GEMINI<sub>3</sub>***



***SUNBURST<sub>3</sub>***



***PHOENIX<sub>3</sub>***



***TRI-STAR<sub>3</sub>***



***ROCKET<sub>3</sub>***

*The Otterbine Sub-Triton<sub>2</sub> is an aeration system that transmits oxygen directly into the water while staying virtually unnoticed.*

## **Where to find it:**

Aerator Equipment .....	4
Electrical Installation .....	4-5
Timer Operation .....	5
Power Control Center Schematics (60Hz and 50Hz) .....	6-8
Physical Installation .....	9-12
• Mooring .....	10
• Screen Assembly .....	11
• Important Electrical Tests .....	12
Technical Specifications .....	13
Annual Maintenance and Special Warnings .....	14
Trouble Shooting Guide .....	15
Exploded Parts Drawing .....	16-18
Otterbine Warranty .....	19

Last Update: 11/25/02

# Aerator Equipment

Unpack and inspect your aerator, report any damage to the carrier that delivered your aerator. Make sure you have received the following:

- 1. Aerator** - you will find a label located on the housing of the aerator. Check the label to make sure you have received the correct horsepower and voltage aerator.
- 2. Power Control Center** - you will find a label inside of the Power Control Center door. This label lists the voltage and horsepower of the control center. Verify that the aerator and control center are the same horsepower and voltage.
- 3. Power Cable** - verify that you have received the correct length.
- 4. Warranty Registration Card** - make sure to fill in your Otterbine warranty registration card and send it back to the factory so that we can send you our bi-annual customer newsletter, which will keep you up to date on all the latest aeration news. **WARRANTY IS VOID UNLESS CARD IS RETURNED.**

## Electrical/PCC Installation

This weather resistant NEMA 3R Power Control Center comes complete with a twenty-four hour on/off timer, magnetic contactor with overload relay, surge arrestor, disconnect, overcurrent protection, HOA switch, and ground fault protection (where applicable). All internal connections are pre-wired. All electrical specifications are located on the door of the Otterbine Power Control Center. Otterbine recommends that all **ELECTRICAL WORK BE DONE BY A QUALIFIED, LICENSED ELECTRICIAN**. Make sure that all electrical work conforms with local, state and national electrical codes.

**NOTE:** Otterbine suggests coordinating electrical installation with physical installation. The electrician will need to be on hand for a two minute dry-run test of the unit and will also need to check the running amperage after installation. **These electrical tests are a crucial part of the installation process and should not be ignored.**



### A. Install the Otterbine Power Control Center as close to the pond as possible.

**CAUTION:** The Power Control Center should not be accessible from the water.

**ATTENTION:** la loite de control ne doit pas être accessible de l'eau.

**WARNING:** Screw connections may loosen during shipping, verify that all screw connections are tight before energizing PCC.

**CAUTION:** Otterbine recommends that the PCC not be mounted in direct sun light when installed outdoors.

### B. Your Otterbine Power Control Center can be mounted indoors or outdoors.

1. When mounting outdoors Otterbine suggests that you use a piece of exterior plywood and sturdy 4 x 4 post(s).
2. When mounting indoors the PCC can be mounted directly to the wall.

**C. Bring the incoming power into the panel on the opposite side of where the aerator cable is to exit.**

**D. Attach incoming power to the top of the disconnect.** Otterbine recommends that all exterior incoming power cable and exterior aerator cable be encased in conduit.

**E. Attach aerator power cable to the contact points on the overload relay in the Power Control Center.** Make sure to always use Otterbine aerator cable. If Otterbine aerator cable is not used, the **WARRANTY IS VOID**.

**CAUTION:** Each cable should be in its own conduit to avoid nuisance tripping of the GFCI device.

**NOTE:** Wiring schematics are located on the following pages. Please note on all 460V units EPD/GFCI (Equipment Protection Device/Ground Fault Circuit Interrupter) is an optional accessory.

**WARNING:** All Otterbine submersible aeration systems must be installed in conformance with all local, state and national electrical codes. Otterbine aeration systems require the use of GFCI for safe operation. If the proper grounding and GFCI protection are not used, serious or FATAL electrical shock may occur.

**ADVERTISSEMENT:** Otterbine® fortement suggère qu'au panneau de branchement électrique un interrupteur avec control de defaut de masse soit installé, ou les personnes se trouverai près de l'eau.

**SATELLITE CONTROLLERS:** Custom control panels are available as an option for customers using computerized irrigation controllers. These panels will interface with the computer and allow you to run your units(s)/lights(s) remotely. See your local Otterbine distributor or call Otterbine directly for more information.

**WARNING:** A full three phase power supply is recommended for all three phase motors, consisting of three individual transformers or one three phase transformer. So called "open" delta or wye connections are not true three phase power supplies and are likely to cause problems of current unbalance. Open delta or wye power and phase converters often suffer from line unbalance which can cause poor motor performance, nuisance tripping or premature motor failure. **WARRANTY IS VOID** if a factory authorized phase converter is not used.



Earth Ground Symbol (used in PCC)

## Timer Operation

**Note:** There are two types of the timers used depending on the voltage and frequency of your unit. Refer to the appropriate timer instructions.

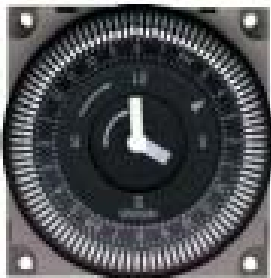

Timer Type A

### Timer Type A (60Hz)

1. Push **in** (towards center) all of the tripper pins on the timer dial.
2. Pull **out** all of the tripper pins on the dial that are between the times you want the unit to run. Example: If you want the unit on from 7:00AM - 5:00PM, you would then pull out all of the tripper pins between those times. When the dial rotates to a tripper pin that is in, it will turn off.
3. Turn the dial clockwise to set the time of day. Close the panel and apply power. In case of power failure, reset timer.



Timer Type B

### Timer Type B (50Hz)

1. Set the timer trippers to the desired run time. Light colored tripper turns the unit on, Dark colored tripper turns the unit off. To move the trippers, loosen the set screw by hand and adjust
2. Turn the dial counter clockwise and align the actual time of day with the time tab point located off of the center of the face and pointing down. To manually operate the timer move the manual selector switch to the on or off position. Close panel and apply power. In case of power failure, reset timer.

### 115 Volt 1 Phase 60 Hertz Schematic

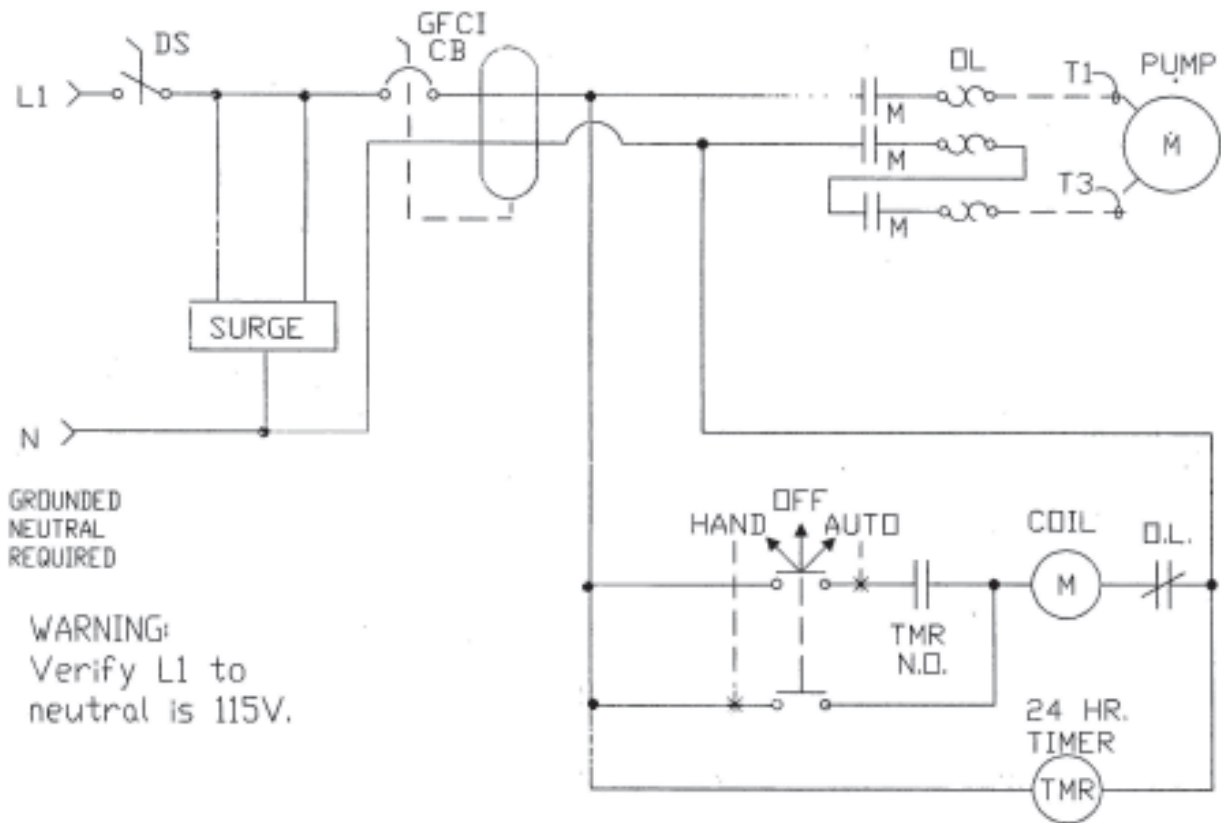

### 208-230 Volt 1 Phase 60 Hertz Schematic

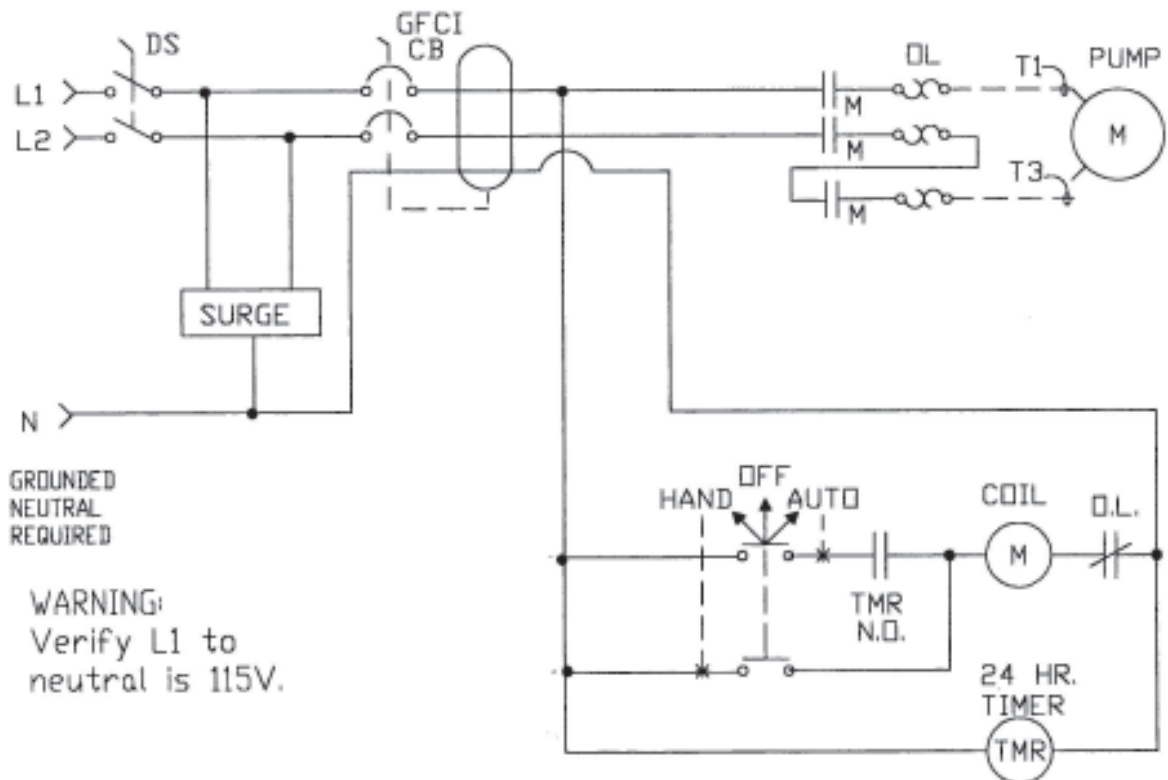

## 208-230 Volt 3 Phase 60 Hertz Schematic

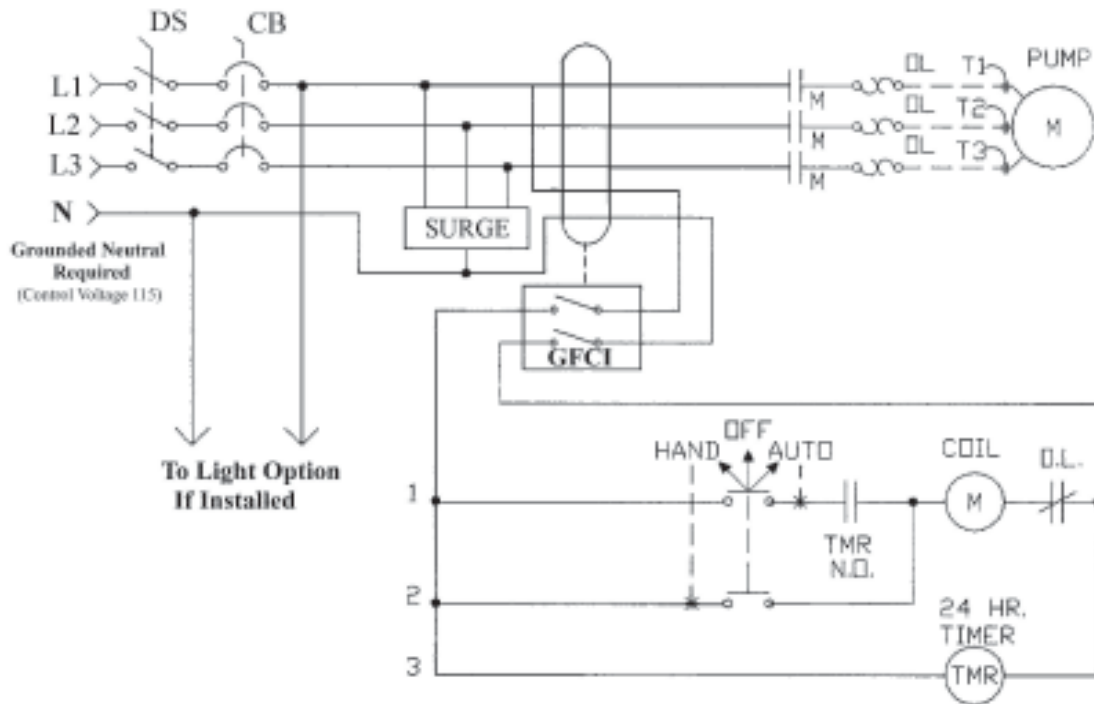

## 460 Volt 3 Phase 60 Hertz Schematic

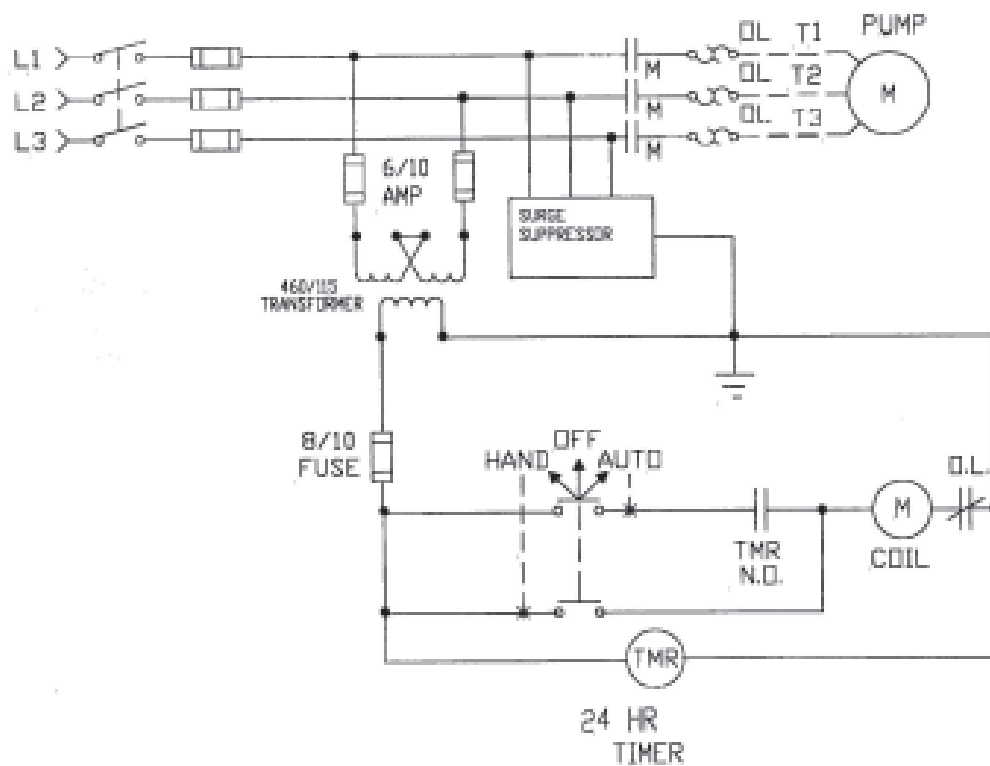

### 220 Volt 1 Phase 50 Hertz Schematic

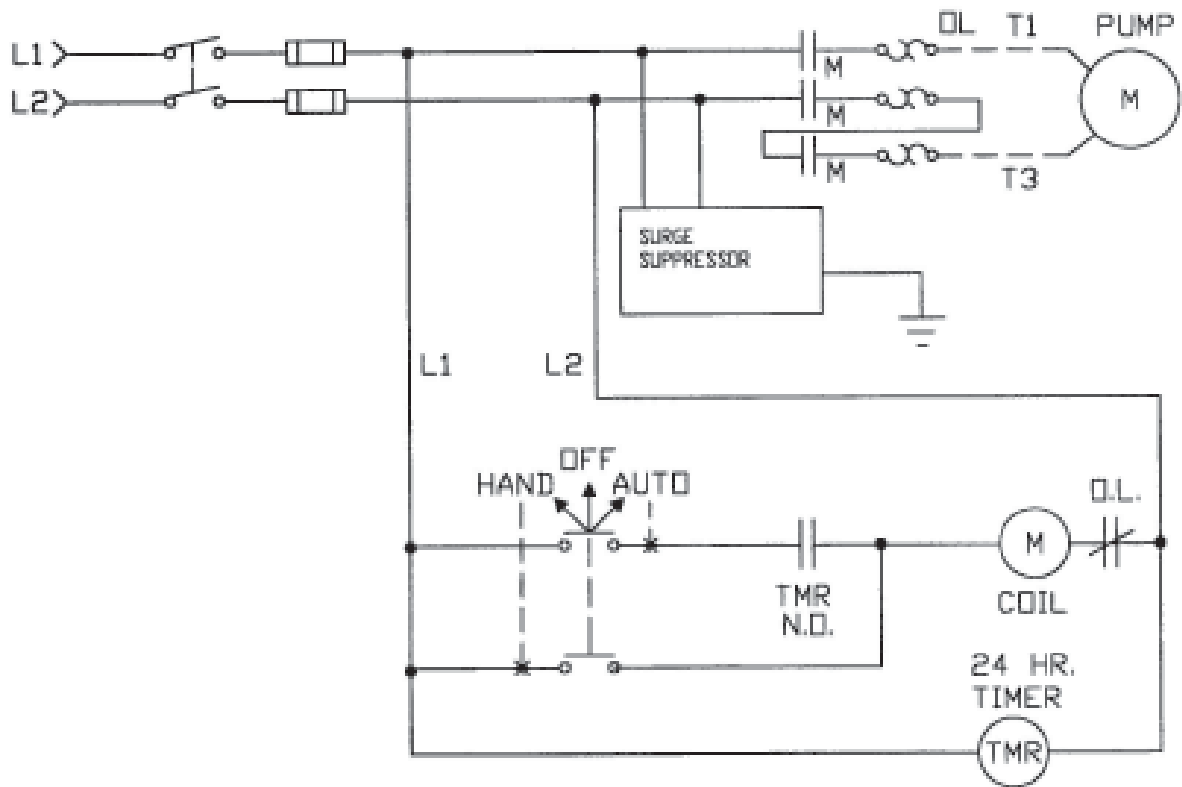

### 380/415 Volt 3 Phase 50 Hertz Schematic

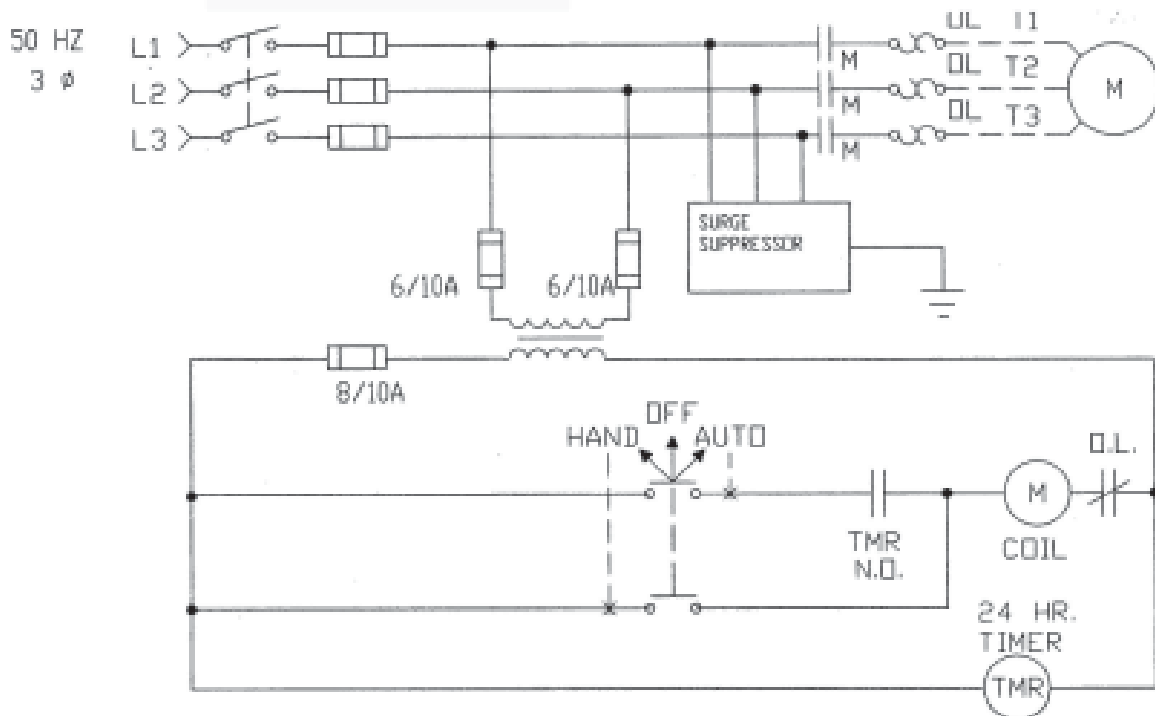



## Physical Installation

Prior to installation please measure your water depth, the TRITON<sub>2</sub> models require at least **48"/1.2m** of water to run properly. If the water is too shallow, dig out a portion of the pond bottom directly under the aerator. If high waves or large fluctuations in water depth occur, it may be necessary to allow for more than the required **48"/1.2m**.

**NOTE:** Mixer model can not be adjusted.

**A. This aspirator model can be adjusted to allow a +/- 20 degree tilt in the discharge.** To adjust remove the bottom bolts securing the power unit to the support frame (one on each side). Loosen the top bolts, and move the unit to align the bolts with the desired holes in the support frame. Install the bolts and secure all loosen/removed bolts.

**NOTE:** You will notice a small amount of silicon compound on the female end of the aerator connector. This compound has been applied during assembly and is needed in order to make proper seal between the two connectors. **DO NOT REMOVE COMPOUND!** When servicing the aerator make sure to re-apply compound (Otterbine part# 48-0001).



**CAUTION: KEEP HANDS CLEAR OF THE  
IMPELLER WHEN STARTING THE AERATOR!**

**ATTENTION: BARDER VOS MAINS Á  
DISTANCE DE LA TURBINE LORSQUE VOUS  
ESSAYEZ DE DÉMARRER L'AÉRATEUR**

**B. Attach your Otterbine power cable to the aerator.** Place the unit on a flat surface with the float down. Align the pigtail connector on the cable up to the pin configuration on the bulkhead connector. **HAND TIGHTEN** the coupling nut onto the bulkhead connector. **DO NOT OVER TIGHTEN - OVER TIGHTENING WILL CAUSE A FRACTURE IN THE CONNECTOR AND COULD RESULT IN A SHORT CIRCUIT.**

**C. Fasten the strain relief to the float.** Using two ty-wraps secure the cable to the side of the support frame and place a small loop in the cable between the last ty-wrap and the connector. **ONLY PLACE A SMALL LOOP IN THE CABLE, DO NOT ALLOW THE CABLE TO TOUCH THE FLOAT.**

**D. Have your electrician perform an on-shore dry-run test:**

**1. Check and compare the actual power supply at the site to the information on the aerator's nameplate in regard to: motor voltage, phase, and frequency. IF VOLTAGE VARIATIONS ARE NOT WITHIN THE RANGE ON THE FOLLOWING CHART, DO NOT OPERATE THE UNIT!**

Voltage	Low	High
115	109	127
208-230	197	250
460	437	495

Voltage	Low	High
380*	380	420
415	400	436
575	546	600

**\*WARNING: A MINIMUM OF 380 VOLTS MUST BE ATTAINED OR THE PROPER STEP-UP TRANSFORMER MUST BE SPECIFIED!**

2. With the aerator on dry land, attach the power cable to the aerator and power supply.
3. Turn the handle mechanism on the exterior of the power control center to the "ON" position.
4. Energize the unit by turning the "Hand, Off/Auto" switch to the "Hand" position. Run the unit 2 minutes to break in seals. **DO NOT RUN UNIT FOR MORE THAN 2 MINUTES -- MOTOR DAMAGE CAN OCCUR.**
5. **IF Steps 1-4 are successful, you are ready to install the unit in the water.** Proceed with following mooring instructions located at the bottom of this page.

### Mooring the Unit

The TRITON must be securely tied in order to keep the unit from moving. The extremely high pumping rates of this unit will literally push the unit in the water if not secured properly. This could put stress on the power cable and connectors and cause a short circuit. **NOTE:** This unit must be moored. It *cannot* be anchored!

**A. You will need the following items in order to moor your Otterbine aerator:**

1. Use all brass and stainless steel hardware in the installation of your Otterbine aerator.
2. Otterbine recommends using 3/32"/.24 cm or 1/8"/32 cm stainless steel cable or 1/2"/1.25cm polypropylene rope for your mooring lines.
3. At the mooring points themselves you will need a wooden stake, 1/2"/1.25 cm of rebar or a "duck bill" type earth anchor --See Figure 1. (Otterbine strongly suggests using earth anchors for installation. See your local Otterbine distributor for more information.)

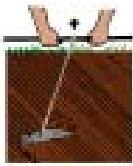
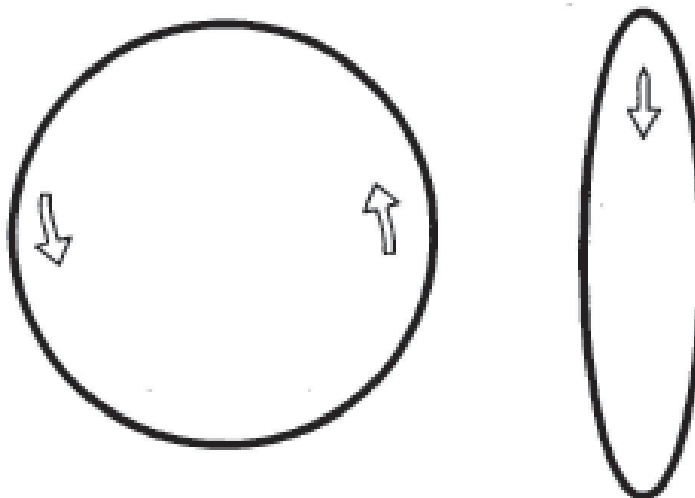

Figure 1

- Duckbill Earth Anchors are driven into the ground, using a drive rod and heavy hammer, compacting the earth as they drive downward, until they reach the recommended depth. After removing drive rod, installer pulls up on cable. This planes or rotates the anchor into load lock position, like a toggle bolt in undisturbed earth.

**B. Choose a suitable location for your Otterbine aerator.** See the aerator location chart below.



**NOTE:** Screen not used on Mixer model.

**NOTE:** Steps C through F apply to the Aspirator model only. If a Mixer model is being installed proceed to Step G.

**C. Place the screen assembly (PART# F-900-003) over the unit.** Pull the mooring cable out through the sides of the screen at a 45 degree angle toward the front of the unit to allow proper mooring. (see Figure 2)

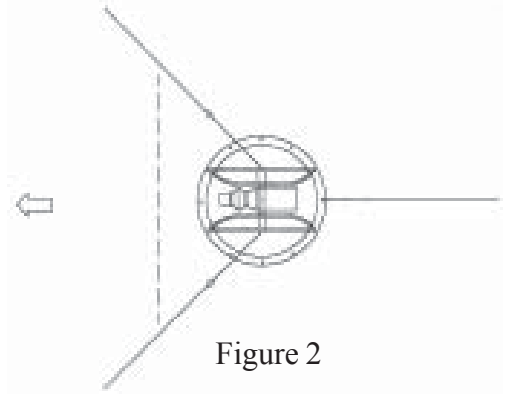

**D. Place the cord through the trough of the float.** Using eight ty-wraps, fasten the screen to the support frame. Place one tyrap on each corner below the bottom side support. Using another 4 ty-raps secure the bottom of the screen to the support frame close to each corner.

**E. Fasten the screen to both sides of the trough containing the cable, using (2)#10 screws and (2) washer.** Secure the screen to this side of the float in another location closer to the front of the unit.

**F. On the opposite side, secure the screen to the float in the same manner as in step E.**

**G. Fasten a mooring line to the 1/2" hole in the rear of the float.** Fasten a mooring line to each of mooring cables. (Refer to Figure 2)

**H. Launch your aerator into the water.** Secure the two front mooring lines to stakes at or near the shoreline. The angle between line 1 and line 2 should be 90 degrees.

**I. Pull your Otterbine aerator into your previously chosen location.**

**J. Put in the other anchor or stake.**

**K Pull the third mooring line tight and secure it to a stake as mentioned above.**

**NOTE:** Make sure all mooring lines are tight. Check them occasionally to make sure they are secure.

**L. Energize your unit.**

**M. Have your electrician do the following while the unit is in the water under load.**

**1 PHASE UNITS:** Record running voltage and running amperage, power control center serial#, and cable length and size (gauge) on the sticker inside the power control panel.

Proceed to step N.

**3 PHASE UNITS:** OTTERBINE® aerators are designed to run in a COUNTER CLOCKWISE DIRECTION. CURRENT UNBALANCE BETWEEN THE LEGS ON 3 PHASE UNITS SHOULD NOT EXCEED 5%. Steps 1-6 below will help determine current unbalance.

**1. Check the direction of the rotation.** Three-phase motors can run in either direction depending on how they are connected to the power supply. When the three cable leads are first connected to the power supply, there is a 50% chance that the motor will run in the right direction.

**2. Establish the correct motor rotation by running in both directions.** Change rotation by exchanging any two of the three motor leads. **The rotation that gives the lowest current readings is always correct. Failure to do the above MAY CAUSE THE MOTOR TO FAIL WITHIN ONE WEEK OF RUNNING TIME. MOTOR FAILURE DUE TO REVERSED POLARITY WILL NOT BE COVERED UNDER WARRANTY.**

**NOTE:** On Mixer model, verify water flow direction as shown in Figure 2.

**3. Check current readings in amps on each leg using the three possible hook-ups.** Roll the motor leads across the starter in the same direction to avoid motor reversal. EXAMPLE:

**4. Calculate the percent of current unbalance:**



**A. Add the three line amp values together.**

**B. Divide the sum by three, yielding current average.**

**C. Pick the amp value that is furthest from the average current (either high or low).**

**D. Determine the difference between this amp value (line C) and the avg (line B).**

**E. Divide this difference (line D) by the average (line B).**

**F. Multiply the result (line E) by 100 to determine percent of unbalance.**

**5. Current unbalance should not exceed 5% at the service factor load.** If unbalance cannot be corrected by rolling leads, locate source of unbalance & correct it. IF leg furthest from average stays on the same power lead, THEN the primary cause of unbalance is the power source. IF leg furthest from average moves on each of the hookups with a particular motor lead, THEN the primary cause of unbalance is the "motor side" of starter. Consider: damaged cable, leaking splice, poor connection, or faulty motor as possible causes.

**6. Record running voltage & running amperage, power control center serial #, and cable length and size (gauge) on the sticker inside the power control panel.**

**N. Lock your enclosure with a padlock to prevent any type of vandalism.** Set the "hands off" switch located on the outside of your Power Control Center to the HAND or AUTO position. The "HAND" position on the switch will let your aerator run continuously. The AUTO position on the switch will allow the automatic timer inside your aerator to operate the unit. See timer operating instructions. Your aerator should be running at this point and installation is complete.

**CAUTION:** The aerator should be allowed to run continuously for 12 hours after installation. This will allow the aerator to properly "break in."

**ATTENTION:** l'aérateur doit être permis de fonctionner continuellement pendant 12 heures après l'installation. Cel permettra a l'aérateur d'être proprement rodé.

## Technical Specifications - Aspirating Model

Model	HP	Voltage and Phase	Motor RPM	Running Amp Draw	**Pond Volume Influenced ft <sup>3</sup>	Min. Depth	Shipping Weight*
<b>100</b>	1	115 1Ph	1725@60Hz	12.6	210,000	2.5'	202 lbs.
	1	208-230 1Ph	1725@60Hz	6.5	210,000	2.5'	202 lbs.
	1	220 1Ph	1425@50Hz	7.3	794,850 liters	80 cm	92 kilos
<b>200</b>	2	208-230 1Ph	1725@60Hz	11.5	420,000	2.5'	202 lbs.
	2	220 1Ph	1425@50Hz	12.0	1,589,700 liters	80 cm	92 kilos
<b>300</b>	3	208-230 1Ph	1725@60Hz	12.5	630,000	2.5'	202 lbs.
	3	220 1Ph	1425@50Hz	14.5	2,384,550 liters	80 cm	92 kilos
	3	208-230 3Ph	1725@60Hz	8.7	630,000	2.5'	205 lbs.
	3	380 3Ph	1680 @60Hz	4.7	610,000	2.5'	205 lbs.
	3	460 3Ph	1725@60Hz	4.1	630,000	2.5'	205 lbs.
<b>500</b>	3	380/415 3Ph	1425@50Hz	4.3	2,384,550 liters	80 cm	93 kilos
	5	208-230 3Ph	1725@60Hz	13.5	1,050,000	2.5'	205 lbs.
	5	380 3Ph	1680 @60Hz	7.5	1,022,000	2.5'	205 lbs.
	5	460 3Ph	1725@60Hz	7.0	1,050,000	2.5'	205 lbs.
	5	380/415 3Ph	1425@50Hz	6.2	3,974,250 liters	80 cm	93 kilos

\*Shipping weight includes unit, 50' or 16.7 meters of cable and power control center. \*\*Pond Volume influenced based from empirical data and may vary due to voltage, elevation, and relative humidity.

## Technical Specifications - Mixer Model

Model	HP	Voltage and Phase	Motor RPM	Running Amp Draw	**Pond Volume Influenced ft <sup>3</sup>	Min. Depth	Shipping Weight*
<b>100</b>	1	115 1Ph	1725@60Hz	12.6	490,000	3'	202 lbs.
	1	208-230 1Ph	1725@60Hz	6.5	490,000	3'	202 lbs.
	1	220 1Ph	1425@50Hz	7.3	1,854,650 liters	1m	92 kilos
<b>200</b>	2	208-230 1Ph	1725@60Hz	11.5	980,000	3'	202 lbs.
	2	220 1Ph	1425@50Hz	12.0	3,709,300 liters	1m	92 kilos
<b>300</b>	3	208-230 1Ph	1725@60Hz	13.7	1,470,000	3'	202 lbs.
	3	220 1Ph	1425@50Hz	12.5	5,563,950 liters	1m	92 kilos
	3	208-230 3Ph	1725@60Hz	8.8	1,470,000	3'	205 lbs.
	3	460 3Ph	1725@60Hz	4.2	1,470,000	3'	205 lbs.
	3	380 3Ph	1680 @60Hz	4.7	1,430,000	3'	205 lbs.
3	380/415 3Ph	1425@50Hz	4.0	5,563,950 liters	1m	93 kilos	

\*Shipping weight includes unit, 50' or 16.7 meters of cable and power control center. \*\*Pond Volume influenced based from empirical data and may vary due to voltage, elevation, and relative humidity.

## Maintenance

Your Otterbine TRITON<sub>2</sub> aerator requires periodic maintenance:

**A. Once a year, disconnect the unit from the power source and physically inspect the aerator and underwater cable for any cuts, cracks, or breaks in the power cable and connector.** These may cause oil leaks and/or electrical shorts. Inspect and clean the pumping chamber components.

**B. After every three operating seasons, a simple oil change is necessary to keep your unit running smoothly.** Please contact your local Otterbine distributor to order a maintenance kit, PART# C2-MKIT.

When a unit is properly cared for it will give you years of trouble free service. If any problems arise, please contact your Otterbine distributor or the factory directly at 1-800-AER8TER.



**WARNING: DISCONNECT THE UNIT FROM THE POWER SOURCE BEFORE SERVICING THE UNIT!**



### WARNING:

- Aerators located in or near swimming pools, garden ponds and similar locations must be equipped with GFIC Protection Devices. Please see your local Otterbine distributor for price and availability.
- The permissible temperature range for this equipment is -12° to 40° C/10° to 104° F.
- It is possible for the water to become slightly polluted in the rare case that an oil leakage occurs.
- If the power cord is damaged, it must be replaced by a special cord or assembly available from Otterbine/Barebo, Inc. or an authorized Otterbine/Barebo, Inc. sales and service center.

### ADVERTISSEMENT:

- Les aérateurs situés à courte distance ou proche de piscines, étangs de jardin et semblable endroits doivent être équipés avec un interrupteur avec contrôle de défaut. S'il vous plaît voyez votre distributeur d'Otterbine local pour prix et responsabilité.
- La gamme de température permet pour cet équipement est de -12 à 40C/10 à 104F.
- Si la corde électrique est abimée, elle doit être remplacée par une corde spécial ou assemblage disponible d'Otterbine®/Barebo, Inc. ou par un centre de service de vente autorisé par Otterbine®/Barebo, Inc.
- L'eau pourrait devenir légèrement polluée dans le très rare cas où l'huile fuirait.

## Trouble Shooting Guide

SYMPTOM	POSSIBLE CAUSE	CORRECTION
1) No bubbles in water discharge (Aspirating model only)	Clogged air hose Cut or broken hose Motor running clockwise	Remove debris Replace hose Have electrician switch two wires at starter
2) No water discharge	Debris around impeller Broken impeller	Remove debris Replace impeller
3) Aerator is wandering	Broken mooring line Loose mooring line	Replace broken line Tighten mooring line
4) Severe vibration	Unit resting on bottom Broken Impeller	Move to deeper part of pond Replace Impeller
5) Motor will not start	Blown fuse/breaker Relay has tripped Broken or disconnected wires GFIC device has tripped Short in power cable	Check fuses or breaker at P.C.C. Check if overload relay tripped Replace or attach loose or broken wires Reset and test GFCI device. If device trips again call electrician or authorized service center. Check condition of power cable

**NOTE:** Most problems will be found by pulling the aerator out of the water.



**WARNING: DISCONNECT THE UNIT FROM THE POWER SOURCE BEFORE SERVICING THE UNIT!**



# Otterbine® Triton<sub>2</sub> Exploded Parts Drawing

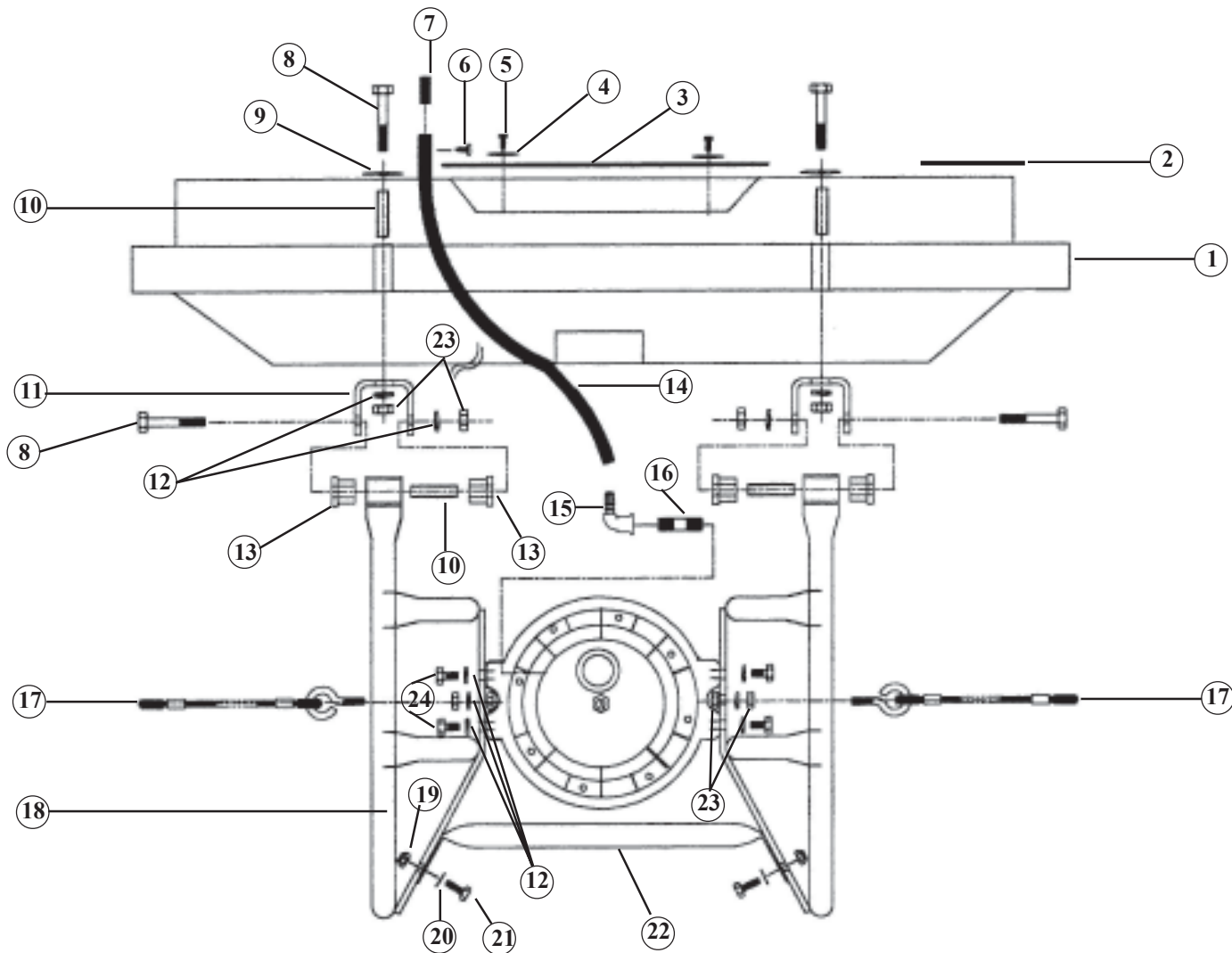

Item	Description	Qty.	Part #	Item	Description	Qty.	Part #
1	C2 Float	1	C2-400	20	5/16" Flat Washer	4 (2)	927-004
2	Warning Decal	1	293-005	21	5/16" Bolt	2	106-302
3	Top Screen	1	15-0007	22	Support Brace	1	40-0003
4	3/16" Flat Washer	4	800-011	23	3/8" Hex Nut	12	MP2001
5	#10 Screw 3/4"	4	BP2803B	24	3/8" Bolt	4	C2-111
6	#8 Screw 1/2"	1 (0)	GP8506	<b>Items not illustrated</b>			
7	Muffler	1 (0)	46-0005				
8	3/8"-16x3" Bolt	8	22-0004	25	Screen Assy w/ hardw.	1	F-900-003
9	3/8" - Fender Washer	4	927-009	26	Ty-rap	10	GP5008
10	2" Spacer	8	40-0005	<p><b>Note:</b> Quantity in "(" is for Mixer model if different than aeration model. *Part number depends on model and horsepower rating.</p>			
11	U Bracket	4	40-0004				
12	3/8" Lock Washer	15 (14)	EP6301				
13	Bushing	8	41-0002				
14	Air Tube	1 (0)	46-0004-034				
15	Elbow Fitting	1(0)	46-0007				
16	PIpe Nipple	1 (0)	46-0006				
17	Mooring Cable Assm.	2	10-0010				
18	Support Frame	2	10-0009				
19	5/16-18 Lock Nut	4(2)	GP1208				



# Otterbine® Triton<sub>2</sub> Aeration Model Pumping Chamber

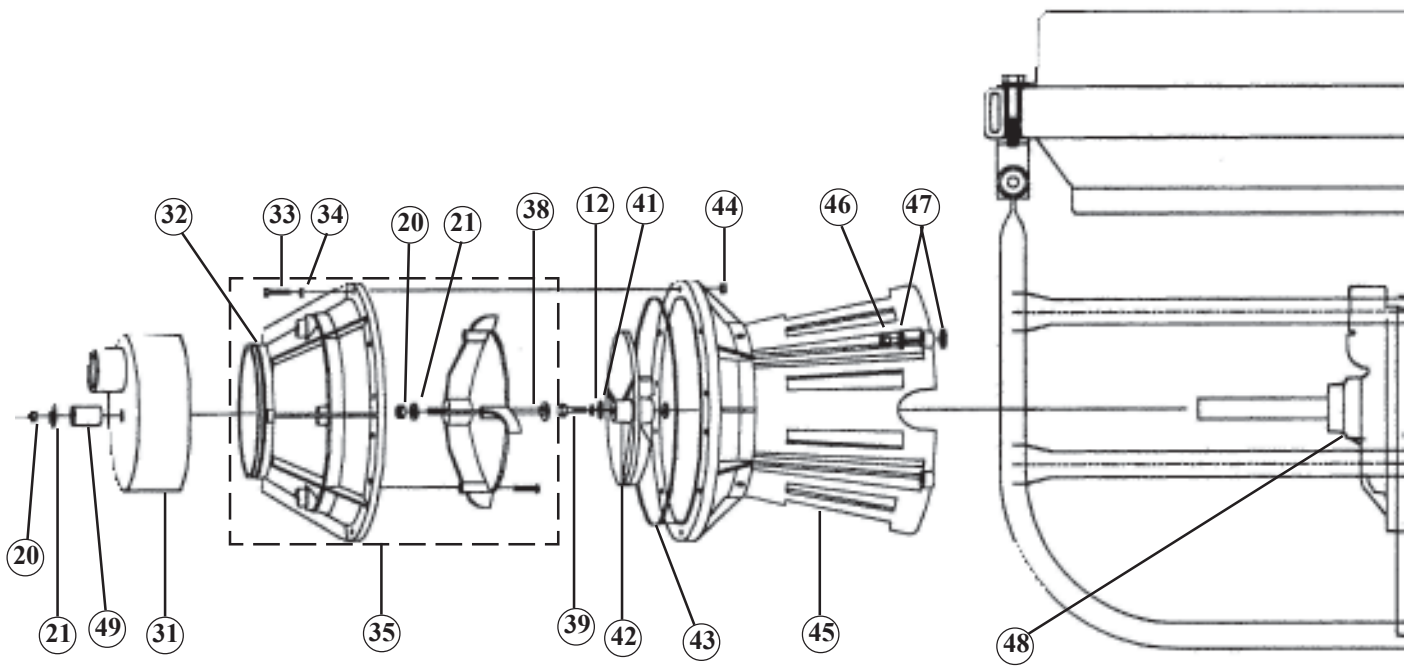

**Note:** Quantity in "( )" is for Mixer model if different than aeration model.  
 \*Part number depends on model and horsepower rating.

Item	Description	Qty.	Part #
12	3/8" Lock Washer	15 (14)	EP6301
20	5/16"-18 Lock Nut	4 (2)	GP1208
21	5/16" Flat Washer	4 (2)	927-004
31	Venturi Assembly	1 (0)	10-0013
32	Manifold O Ring	1 (0)	49-0018
33	10-24 x 1.25" Bolt	8 (0)	MP2004
34	#10 Flat Washer	8 (0)	GP5011
35	Volute Manifold Assy	1 (0)	10-0006
38	5/16-18x5 3/4 Carr. Bolt	1 (0)	C2-140
39	3/8-16x 1.25 Bolt	1 (0)	22-0018
41	3/8" Flat Washer	1 (0)	927-003
42	Impeller, 1HP/60Hz only		C2-811
	Impeller, 1HP/50Hz only		C2-816
	Impeller, 2HP/60Hz only		C2-812
	Impeller, 3HP/60Hz only		C2-813
	or 2HP/50Hz		
	Impeller, 5HP/60Hz only		C2-815
	or 3HP/50Hz		
	Impeller, 5HP/50Hz only		C2-817
43	Pump Chamber O Ring	1 (0)	C2-706
44	10-24 Lock Nut	8 (0)	GP1207
45	Strainer/Lytr Cham Assy.	1 (0)	10-0005
46	1/4" Lock Nut	4 (0)	C2-112
47	1/4" Flat Washer	8 (0)	927-000
48	Power Uni	**	**
49	Spacer, 1.375" long	1(0)	895-0045

# Otterbine® Triton<sub>2</sub> Mixer Option

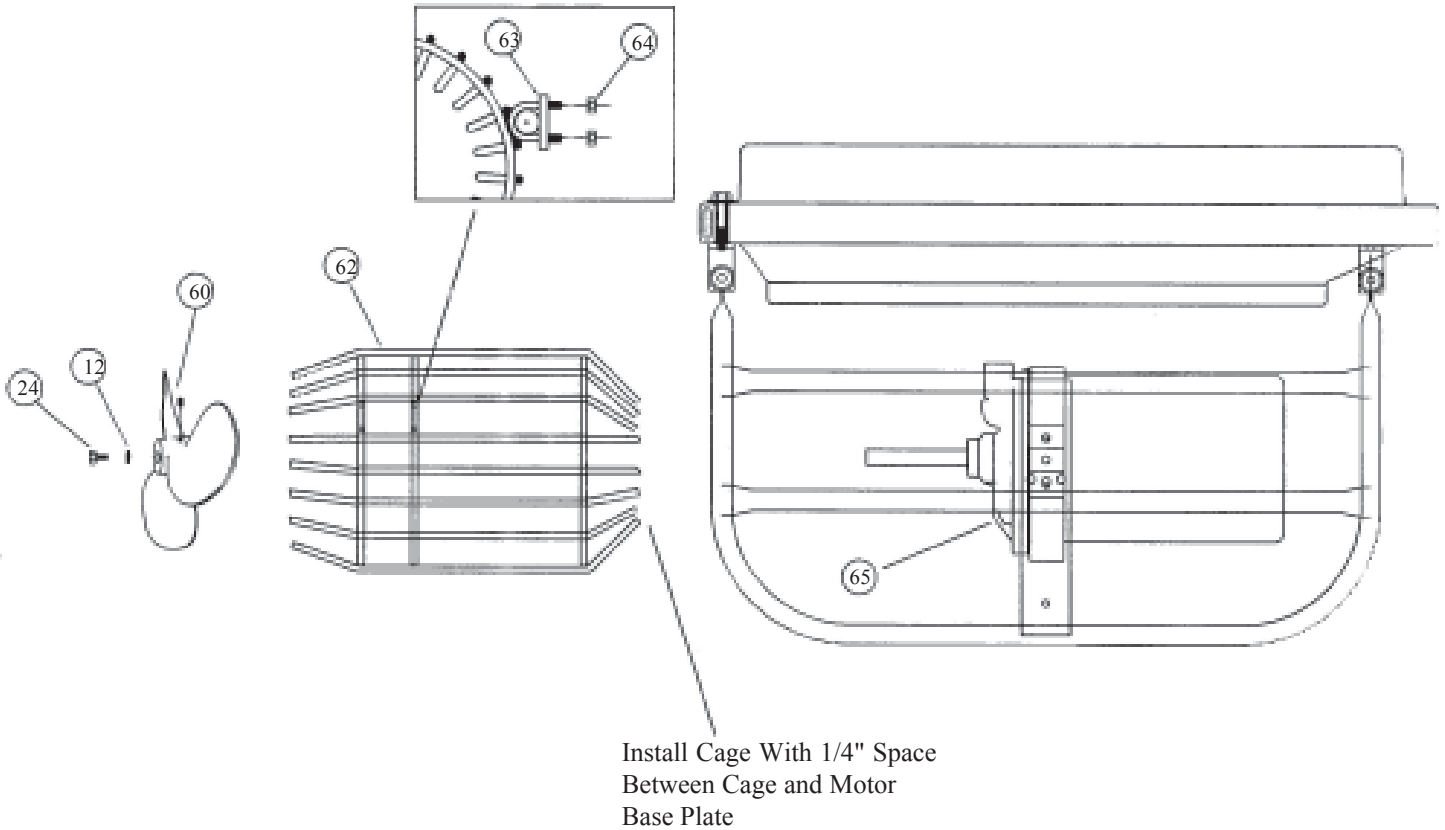

Item	Description	Qty.	Part #
12	3/8" Lock Washer	0 (1)	EP6301
24	3/8" Hex Bolt	0 (1)	C2-111
60	Mixer Impeller w/ Screw		
	1HP 60Hz	0 (1)*	50-0006-001
	2HP 60Hz/1HP 50Hz		50-0006-002
	3HP 60Hz/2HP 50Hz		50-0006-003
	3HP 50Hz		50-0006-053
62	Protective Cage	0 (1)	C2-340
63	Cage Clamp	0 (4)	C2-345
64	1/4" Lock Nut	4 (8)	C2-112
65	Motor Base Plate	Ref.	Reference Only

11/25/02

**Note:** Quantity in "( )" is for Mixer model if different than aeration model.

\*Part number depends on model and horsepower rating.

**Limited 3 year (moving and related parts)  
+ 5 year (non-moving parts) Warranty  
Otterbine® Product**

**WARRANTY:** Barebo, Inc 3840 Main Road East, Emmaus Pennsylvania 18049,U.S.A. hereby warrants, subject to the conditions hereinbelow set forth, that should the **OTTERBINE** product prove defective by reason of improper workmanship or materials at any time during the warranty period the Purchaser at retail will be guaranteed that **BAREBO** will repair or replace the said **OTTERBINE** product as may be necessary to restore it to satisfactory operating condition, without any charge for materials or labor necessarily incident to such repair or replacement, provided that:

- a) The enclosed Warranty Registration Card should be mailed to **BAREBO** within fifteen (15) days of the original receipt by the Purchaser at retail in order to avoid delays:
- b) The **OTTERBINE** product must be delivered or shipped, prepaid, in its original container or a container offering an equal degree of protection, to **BAREBO** or a facility authorized by **BAREBO** to render the said repair or replacement services or, if purchased from an authorized **OTTERBINE** dealer, to such dealer;
- c) The **OTTERBINE** product must not have been altered, repaired or serviced by anyone other than **BAREBO**, a service facility authorized by **BAREBO** to render such service, or by an authorized **BAREBO** dealer, and the serial number of the **OTTERBINE** product must not have been removed or altered: and
- d) The **OTTERBINE** product must not have been subjected to lightning strikes and other Acts of God, vandalism, freezing-in, accident, misuse or abuse, and must have been installed in conformance with applicable electrical codes (including proper electrical protection), and also installed, operated and maintained in accordance with guidelines in the Owner's Manual shipped with the Otterbine product.

No implied warranties of any kind are made by **BAREBO** in connection with this **OTTERBINE** product, and no other warranties, whether expressed or implied, including implied warranties of merchantability and fitness for a particular purpose, shall apply to this **OTTERBINE** product. Should this **OTTERBINE** product prove defective in workmanship or material, the retail Purchaser's sole remedy shall be repair or replacement as is hereinabove expressly provided and, under no circumstances, shall **BAREBO** be liable for any loss, damage or injury, direct or consequential, arising out of the use of, or inability to use, the **OTTERBINE** product, including but not limited to retail Purchaser's cost, loss of profits, goodwill, damages due to loss of product or interruption of service, or personal injuries to Purchaser or any person.

AERATOR MODEL \_\_\_\_\_

HORSEPOWER \_\_\_\_\_

VOLTAGE \_\_\_\_\_ PHASE \_\_\_\_\_ FREQUENCY \_\_\_\_\_

CORD LENGTH \_\_\_\_\_

UNIT SERIAL NUMBER \_\_\_\_\_

PCC SERIAL NUMBER \_\_\_\_\_

OPTIONS \_\_\_\_\_



## Water Works With Otterbine!

Otterbine Barebo, Inc.  
3840 Main Road East  
Emmaus, PA. 18049  
U.S.A.

1-800-AER8TER • (610) 965-6018

FAX: (610) 965-6050

[www.otterbine.com](http://www.otterbine.com)