

MIXER: TRITON & SUB-TRITON INDUSTRIAL AERATOR SPECIFICATIONS

MODEL: The aerator shall be a horizontal circulator with a “jet type” pump. Two configurations: **Triton** (floating) or **Sub-Triton** (submerged).

PUMPING CAPACITIES: The pumping capacity of the aerator shall be sufficient to influence _____ cubic feet (_____ cubic meters) of water.

FLOAT (TRITON ONLY): The float shall be made of seamless, one-piece high-density polyethylene plastic, filled with high density closed cell polyurethane foam. The float shall be capable of providing full floatation if the shell is punctured or cracked. Metal floats or those with an internal void for additional ballast are not acceptable.

IMPELLER: The impeller shall be constructed of type 304 stainless steel material connected to the motor by a type 304 stainless steel set screw and stainless steel thrust collar. Flexible shaft couplings are not acceptable.

MOTOR: The motor shall be a _____ HP, _____ volt, _____ phase, _____ HZ oil-cooled, submersible motor operating at 1725 RPM or 50 Hz operates at 1425 RPM. The service factor shall be 1.15. The motor shall operate in a reservoir of Otterbine oil for continuous lubrication of bearings and for efficient transfer of heat through the motor housing wall. Top mounted motors and water-lubricated motors are not acceptable. The rotor shall be dynamically balanced. The winding (stator) wires shall be covered with class F rated insulation designed for complete immersion in oil. The motor shall be attached to a Valox thermoplastic molded upper plate. This plate will house the bearings and upper motor seals (internal and external). The motor shall be protected against oil and water leakage by a combination of rotary seals, stationary seals, and molded rubber “O” rings.

MECHANICAL SEAL: The seal shall be a Viton mechanical spring seal with a 304 st/st spring and ceramic facing. The seal shall be rated for 200 degrees Celsius.

MOTOR HOUSING: The external motor housing shall be a canister formed from deep drawn 316 stainless steel. The top plate shall be constructed of Valox thermoplastic. A Valox boss will provide support and protection for the male electrical connector.

SUPPORT FRAME: The support frame for the aerator shall be constructed of type 304 stainless steel tube welded with a type 308 stainless steel weld. The frame shall minimize vibration of the unit and allow the angle of discharge to be changed from 20 degrees off horizontal either up or down. **SUB-TRITON ONLY:** Bottom barrier component of support frame shall be constructed of 1/4 inch or .64 cm polyethylene.

PROTECTIVE IMPELLER CAGE: The protective cage shall be constructed of a type 304 stainless steel 1/4 ft or .64 cm welded round-stock.

MOORING CABLE LEADS: The mooring or anchor cable leads shall be of 1/8 inch or .32cm diameter by 4ft or 1 meter long, type 300 series stainless steel wire rope.

FASTENERS: All fasteners are to be type 304 or 316 stainless steel.

ELECTRICAL CONNECTORS: The electrical connectors shall consist of a receptacle and a plug constructed of non-conductive polymers. The system shall create a vacuum seal when connected and have a threaded nut system as a backup. The plug shall have a keyway and be threaded into the top plate. The connector system shall be ETL, UL and CSA approved.



www.otterbine.com/mixer



UNDERWATER POWER CABLE: The power cables shall be type SOOW specifically designed for underwater use. The conductors shall be flexible, stranded bare copper 12, 10 or 8 gauge, triple insulated to resist moisture, wicking, cracking, and softening. The outer jacket of the cable shall be a black CPE material. All underwater connections shall be vulcanized. Power cable shall be able to be furnished in unsplined lengths up to one thousand feet (305m) if necessary.

POWER CONTROL CENTER: The electrical components shall be mounted in a NEMA 4X rated enclosure with an externally mounted disconnect switch, and a MANUAL - OFF - AUTO selector switch. The electrical system for all units (115, 208-230, 380-415 & 460V) shall include a non-reversing 600V rated Manual Motor Controller (MMC) with thermal overload and short circuit trip and 24hr digital timer. 115, 208-230 volt, single and three phase units shall include GFCI (Ground Fault Circuit Interrupter) protection. To operate the GFCI and control circuit on 208-230 volt systems a neutral must be present or an optional control transformer may be supplied. The electrical system shall include a lightning arrester, rated for a maximum of 60,000 amperes discharge.

TESTING: A. Safety - The aerator system shall be tested and approved as a unit. Separate component testing not allowed. Unit must be tested by ETL, ETL-C, CE, UL or other accredited testing facilities. B. Performance - Unit must have independent performance testing provided by the University of Minnesota.

WARRANTY: The warranty shall be three years.

ACCEPTABLE MANUFACTURER: This unit shall be an OTTERBINE Mixer Industrial Aerator manufactured by OTTERBINE BAREBO, INC., 3840 MAIN ROAD EAST, EMMAUS, PA 18049 U.S.A.
 PH: (610) 965-6018. WEB: www.otterbine.com

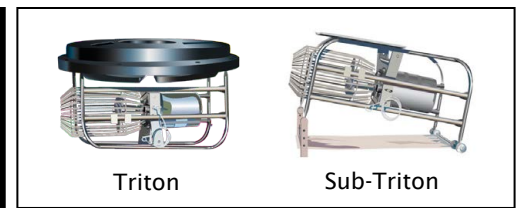
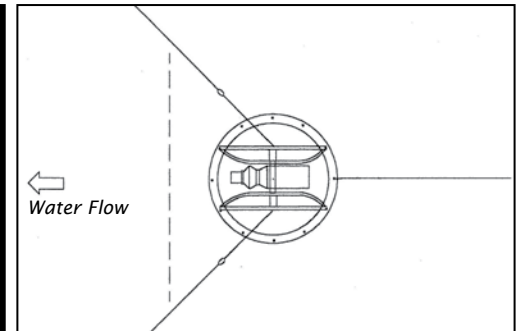

Illustration: Mixers



Installation: Mooring

MODEL: MIXER - TRITON & SUB-TRITON INDUSTRIAL AERATOR										
Motor	HP	Min. Oper. Depth: Triton Mixer ft (m)	Min. Oper. Depth: Sub-Triton Mixer ** ft (m)	Pond Volume Influenced* ft ³ (m ³)	Electrical Rating	Running Amps	Maximum Cable Gauge/Length (†Additional cable options may be available)			Ship Weight ***
							12AWG/4mm ²	10AWG/6mm ²	8AWG/10mm ²	
1725RPM @ 60Hz	1	3 ft	2.5 ft	490,000 ft ³	115V 1Ph	12.6	130m	150ft	250ft	202lbs
					208/230V 1Ph	6.5	375/425ft	600/675ft	950/1000ft	
	2			980,000 ft ³	208/230V 1Ph	11.5	200/225ft	325/375ft	525/600ft	202lbs
					208/230V 3Ph	8.8	350/375FT	550/625ft	900/1000ft	205lbs
	3			1,470,000 ft ³	208/230V 1Ph	12.5	130m	275/325ft	450/500ft	
					460V 3Ph	4.2	1000ft	130m	152m	
1425 RPM @ 50Hz	1	1 m	.8 m	12,488 m ³	220V 1Ph	7.3	130m	206m	305m	92kg
					220V 1Ph	12	69m	114m	183m	92kg
	2			24,976 m ³	220V 1Ph	12.5	130m	99m	152m	93kg
					380/415V 3Ph	4	305m	130m	152m	
	3			37,463 m ³	220V 1Ph	12.5	130m	99m	152m	93kg
					380/415V 3Ph	4	305m	130m	152m	

*Pond volume influenced based on empirical data obtained over a 40-minute period test and may vary due to voltage, elevation, and relative humidity. **For optimal performance, maximum operating depth should not exceed 12ft/3.7m when using the Sub-Triton. *** Shipping weights are estimates and include unit, power control center and 50ft (15m) of cable. (50Hz units do not receive power control center.) 415V and 575V units available upon request. Specifications are subject to change.