



Water Works With Otterbine



CONCEPT₃ Owner's Manual

A Guide to More Dependable
Water Quality Management
With Otterbine Barebo Inc.'s
1, 2, 3 & 5 Horsepower Surface Spray
Aerating Fountain

Welcome Aboard!

Welcome to the growing family of people who depend on aerating fountains for better water quality control and aesthetic improvement. This design offers an industry first five-year warranty with virtually no maintenance, reduced float visibility, and interchangeable spray patterns. All Otterbine products are safety tested and approved by ETL, ETL-C and CE

CONTENTS

SAFETY INSTRUCTIONS 4

INSPECT AERATOR EQUIPMENT..... 5

ELECTRICAL/PCC INSTALLATION 5

UNIT ASSEMBLY 9

PHYSICAL INSTALLATION..... 11

SYSTEM STARTUP 12

MAINTENANCE..... 14

WINTERIZATION 14

SUNBURST PUMP CHAMBER 15

GEMINI PUMP CHAMBER 16

SATURN PUMP CHAMBER..... 17

ROCKET PUMP CHAMBER 18

PHOENIX PUMP CHAMBER 19

TRI-STAR PUMP CHAMBER 20

CONSTELLATION PUMP CHAMBER 21

COMET PUMP CHAMBER..... 22

GENESIS PUMP CHAMBER 23

EQUINOX PUMP CHAMBER 24

OMEGA PUMP CHAMBER 25



WARRANTY 27

Water Quality Specialists

Barebo, Inc. is a team of scientists, engineers, and crafts persons who specialize in efforts to improve water quality. Otterbine aerating fountains are built at Barebo, Inc.'s 25,000 square foot factory in Emmaus, Pennsylvania.

The Concept 3 line of Otterbine aerators, made of stainless steel and high tech engineering plastics, reflects the results of aerator research and development programs that started in 1956, plus the experience gained through thousands of installations on commercial fish farms, golf courses, parks, and architectural applications.

SAFETY INSTRUCTIONS

 WARNING	
	<p>PLEASE READ THIS MANUAL COMPLETELY BEFORE INSTALLING AND USING THIS PRODUCT. SAVE THIS MANUAL FOR FUTURE REFERENCE AND KEEP IN THE VICINITY OF THE PRODUCT.</p>

ALL ELECTRICAL WORK MUST BE PERFORMED BY A QUALIFIED LICENSED ELECTRICIAN AND CONFORM WITH ALL APPLICABLE ELECTRICAL SAFETY CODES

Tous travaux électriques doivent être effectués par un électricien professionnel qualifié et conforme à tous les codes applicables sécurité électrique

ALWAYS SWITCH OFF/DISCONNECT ALL EQUIPMENT IN THE WATER BEFORE SERVICING OR PERFORMING ANY MAINTENANCE

Toujours éteindre l'équipement dans l'eau avant entretien ou de tout entretien

DO NOT OPERATE THE FOUNTAIN WHEN PEOPLE ARE IN THE WATER

Ne pas utiliser la fontaine quand les gens sont dans l'eau

CAUTION: KEEP HANDS CLEAR OF THE IMPELLER WHEN OPERATING!

ATTENTION: Garder les mains loin la turbine lors de l'utilisation!

WARNING





ELECTRICAL SHOCK HAZARD

Disconnect From Electrical Supply
When Servicing This Equipment

Unplug Or Switch Off All Appliances In The
Water Before Carrying Out Maintenance

This Product Must Be Properly Grounded

DANGER

STAY OUT OF WATER WHEN
EQUIPMENT IS ENERGIZED





WARNING

HAZARDOUS VOLTAGE.
Contact may cause
electric shock or burn.
Turn off and lock out
power before servicing.

DANGER

SPINNING IMPELLER
TURBINE ROTATIVE



KEEP HANDS CLEAR
TENIR LES MAINS ÉLOIGNÉE

WARNINGS

- Before entering, wading in or swimming in the water in which Otterbine Aerators or Fountains are installed, make sure they are PHYSICALLY disconnected from their electrical power sources.
- Aerators located in or near garden ponds and similar locations must be equipped with Ground Fault Circuit Interrupter.
- The permissible temperature range for this equipment is -12°C to 40°C (10°F to 104°F)
- It is possible for the water to become slightly polluted in the rare case that an oil leak occurs.
- If the power cord is damaged, it must be replaced by a special cord or assembly available from Otterbine/ Barebo, Inc. or an authorized Otterbine/Barebo, Inc. sales and service center.
- Avant d'entrer, pataugeant dans ou en nageant dans l'eau dans laquelle Aérateurs Otterbine ou fontaines sont installées, assurez-vous qu'ils sont physiquement déconnectés de leur source d'alimentation électrique.
- Aérateurs situés dans ou à proximité des bassins de jardin et des emplacements similaires doivent être équipés de disjoncteur.
- La plage de température admissible pour cet appareil est -12°C to 40°C (10°F to 104°F) aux.
- Il est possible pour que l'eau devient légèrement polluées dans les rares cas où une fuite d'huile se produit.
- Si le cordon d'alimentation est endommagé, il doit être remplacé par un cordon spécial ou de montage disponible à partir Otterbine / Barebo, Inc ou une autorisation Otterbine / Barebo, les ventes Inc et centre de service.

INSPECT AERATOR EQUIPMENT

Immediately report any shipping damage to the carrier that delivered your aerator.

Inspect your aerator and verify the following:

Unit - Check the nameplate located on the housing of the aerator unit to make sure you have received the correct horsepower and voltage aerator.

Power Control Center (PCC) - Verify the PCC is compatible with the aerator unit horsepower and voltage. Refer to the electrical specifications on the nameplate located inside on the door of the PCC.

Power Cable Assembly - Verify the correct cable gauge and length.

For proper warranty consideration return your Otterbine warranty registration card.

ELECTRICAL/PCC INSTALLATION

ELECTRICAL INSTALLATION MUST BE PERFORMED BY A QUALIFIED LICENSED ELECTRICIAN AND CONFORM TO ALL APPLICABLE LOCAL AND NATIONAL CODES

DISCONNECT EQUIPMENT FROM ELECTRICAL SUPPLY BEFORE SERVICING OR PERFORMING MAINTENANCE

Use Only OTTERBINE power cord. Do not splice or repair the cord, replacement is necessary if damage occurs.

The standard Power Control Center includes a fiberglass NEMA 4X enclosure, Hand-Off-Auto switch, twenty-four hour weekly programmable timer (mechanical timer option available) for auto setting, branch circuit protection, motor disconnect, surge protection, motor overload protection, and class A personnel ground fault protection.

Caution: GFCI Protection is required. If GFCI protection is not used, serious or FATAL electrical shock may occur.

Attention: GFCI/RCD de protection est nécessaire. Graves ou mortelles choc électrique peut se produire s'il n'est pas utilisé.

A. Feeder

1. Proper feeder circuit protection in accordance with all applicable local and national codes **must** be provided to the power control center.
2. Be certain to properly size feeder conductors to allow for no more than 5% voltage drop for the entire circuit from the feeder source to the aerator unit. Failure to do so may damage the aerator and void product warranty.

60Hz. Electrical Specifications			
HP	Volts	Phase	Full Load Amps
1	115	1	15.0
1	208/230	1	8.3/7.5
2	208/230	1	13.5/12.0
3	208/230	1	16.6/14.5
3	208/230	3	9.7/8.6
3	380	3	4
3	460	3	4.3
5	230 Only	1	23
5	208/230	3	15.1/13.4
5	380	3	7.6
5	460	3	6.7
5	575	3	5.3

B. PCC Location

1. The power control center should be mounted where easily visible from the shoreline where the aerator is located.

Important: The power control center **shall not** be accessible from the water.

Important: Le Centre de Contrôle de la puissance ne doit pas être accessible à partir de l'eau

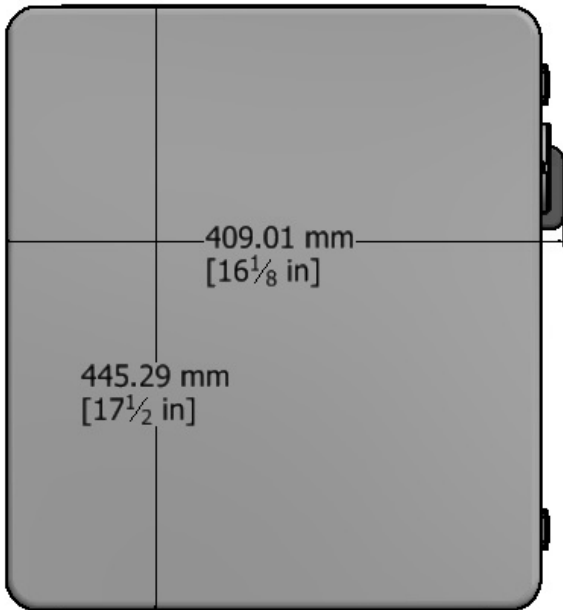

Single Phase – Overall Dimension

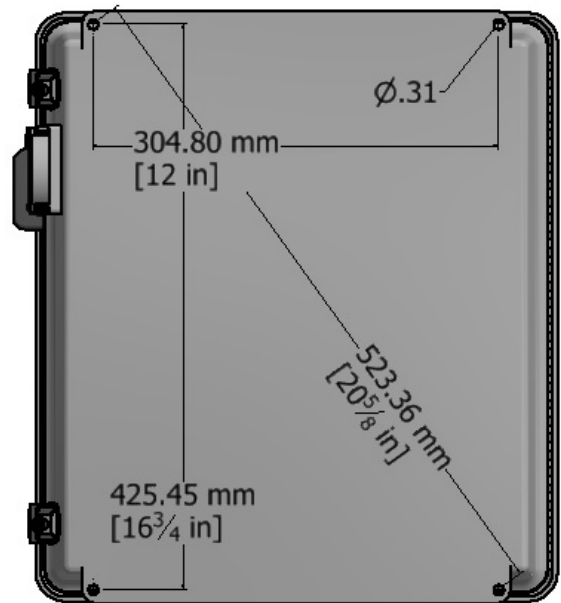

Single Phase – Mounting Hole Layout

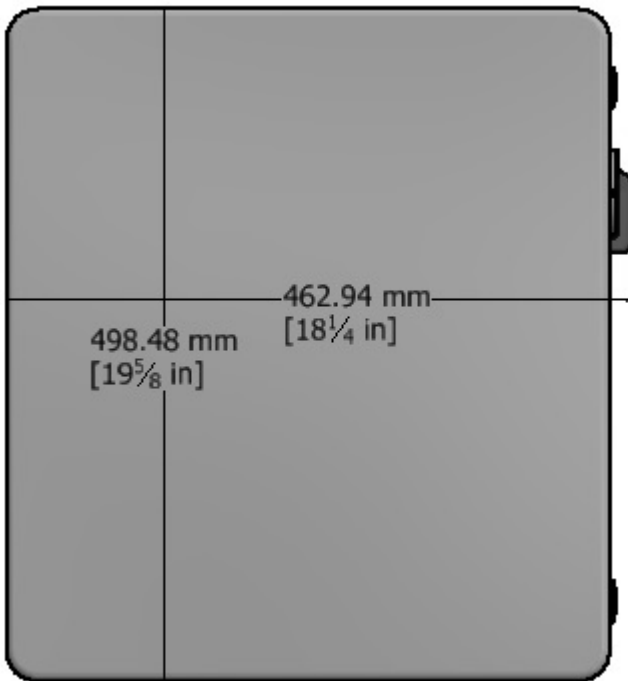

Three Phase – Overall Dimension

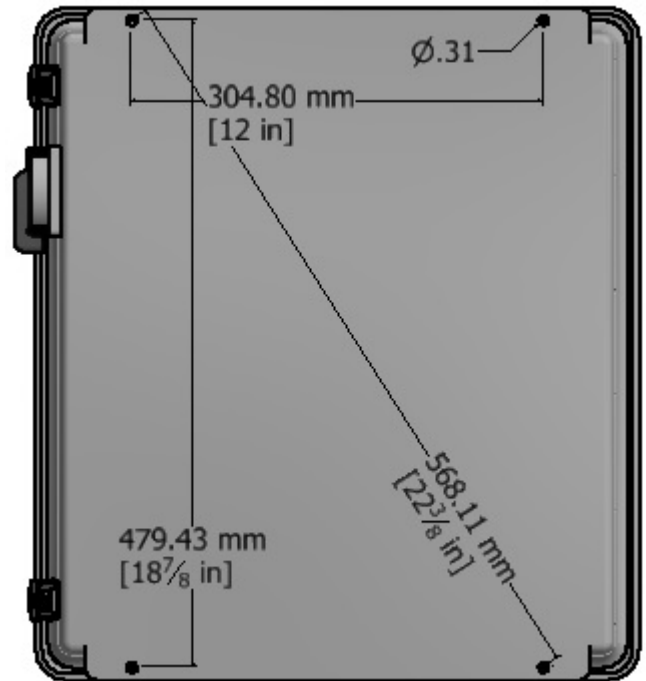

Three Phase – Mounting Hole Layout

C. PCC Mounting

1. To prevent damage to the enclosure mount the enclosure using all four (4) mounting holes.
2. Whenever possible do not mount the PCC in direct sun light.

D. PCC Cables & Connections

1. Only Otterbine Barebo, Inc. factory approved power cord is to be used from the PCC to the aeration unit with no junction boxes or splices. **Only** use power cord gauges and lengths specified by Otterbine at the time of cable purchase. (Contact your Otterbine Distributor for proper cable sizing)
 2. It is recommended that all exposed cable between the PCC and the shoreline be installed in non-metallic conduit. It is **important** that aerator and lighting cables be installed in individual conduits to avoid induced interference between cables which could cause random GFCI tripping.
 3. **Always** use strain relief cord connectors to attach the Otterbine cable to the PCC when not using conduit.
 4. Cables and conduits must only enter into the bottom of the PCC.
 5. Factory connections may loosen during shipping. Verify tightness of all screw terminal connections before energizing.
 6. Power input and output wiring connections are accessed from the bottom of the enclosure.
- Reference label inside enclosure for terminal torque values and wire sizes.



Single Phase Panel

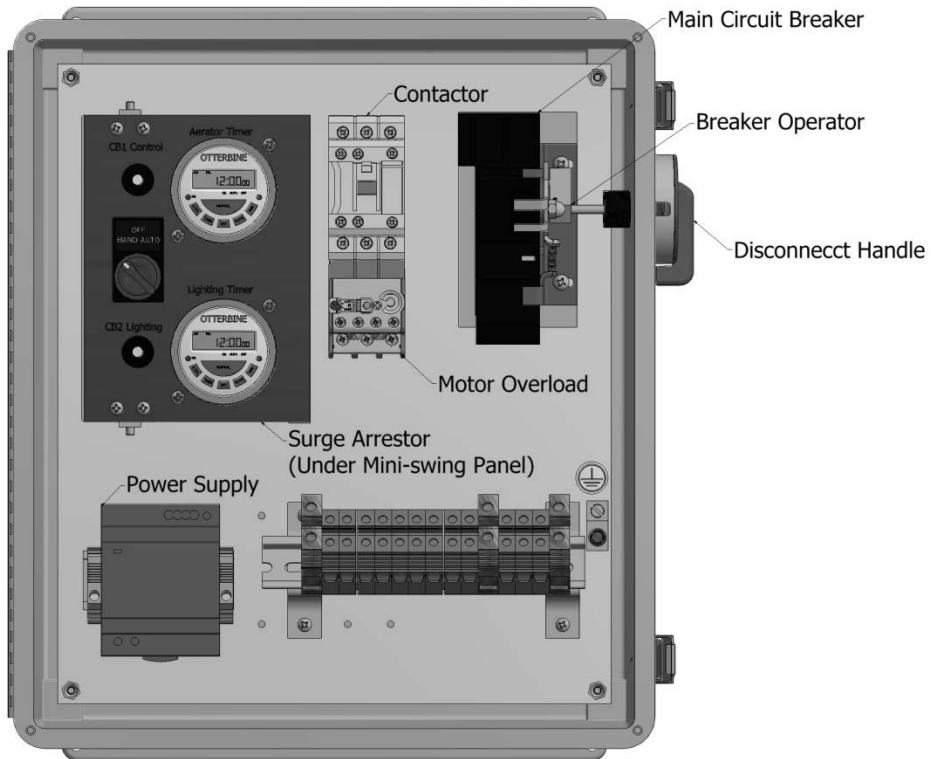

Single Phase Panel – Cover Removed



Three Phase Panel

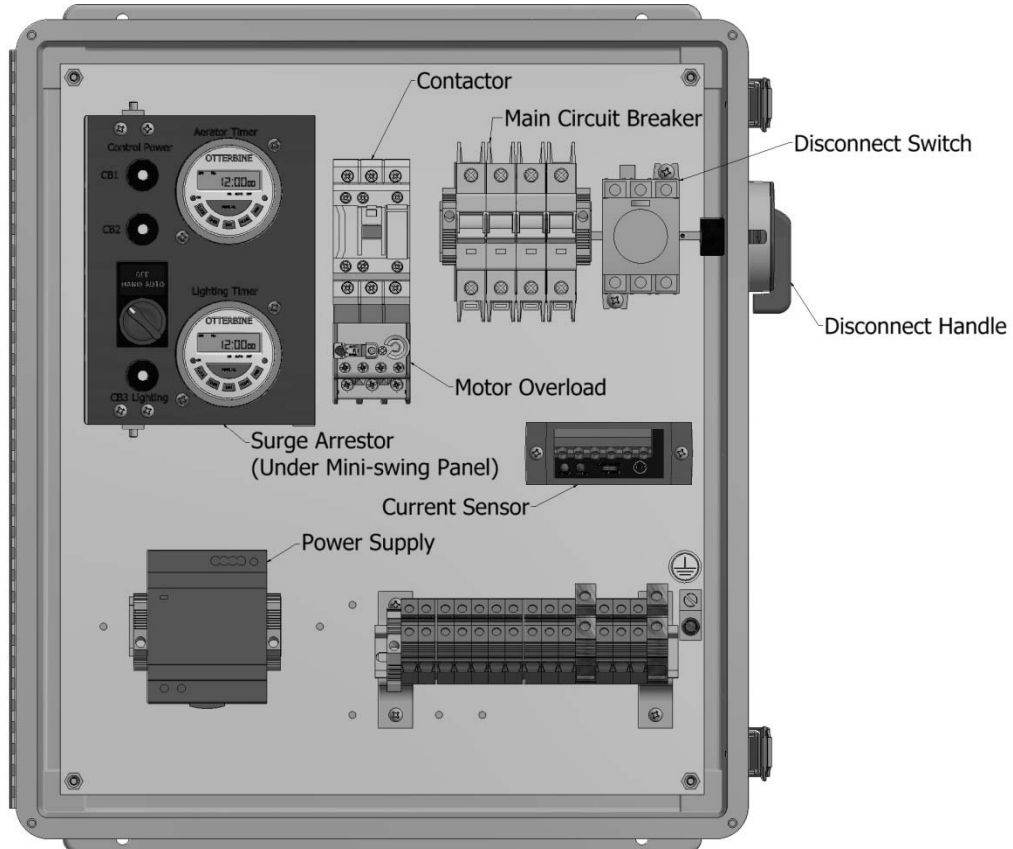

Three Phase Panel – Cover Removed

UNIT ASSEMBLY

READ THE INSTRUCTIONS: Improper assembly may result in damage to the unit.

NOTES:

***Genesis Pump Chamber; The Float MUST be mounted before the Genesis Throat Assembly (Shown on page 22).**
(Domestic units typically ship fully assembled)

***5HP "Open Throat" Units (Sunburst, Gemini, Saturn); If applicable, the Supplemental Float must be mounted to the Main Float before installing on Unit (See Below).**

A. Supplemental Float Assembly

***If the Supplemental Float is already mounted to the Main Float, continue with main float assembly below.**

1. Place Main Float top face down.
2. Place the Supplemental Float on the Main Float as shown in the photo below.
3. Ty-Rap the floats together in four places (1 in each pocket).
4. Continue mounting Main Float.

B. Main Float Assembly

1. Stand the unit upright and place the float onto it so the holes in the float line up with the holes in the mounting brackets.
2. Place a fender washer onto a hex bolt and insert into one of the four holes in the float making sure it also goes through the hole in the steel mounting bracket on the unit. Repeat this for the three remaining holes.
3. Place a flat washer and a nylon locknut onto each of the four hex bolts. Tighten each nylon locknut.

CAUTION: Do not over tighten lock nuts, damage may occur to the float and/or pump chamber.

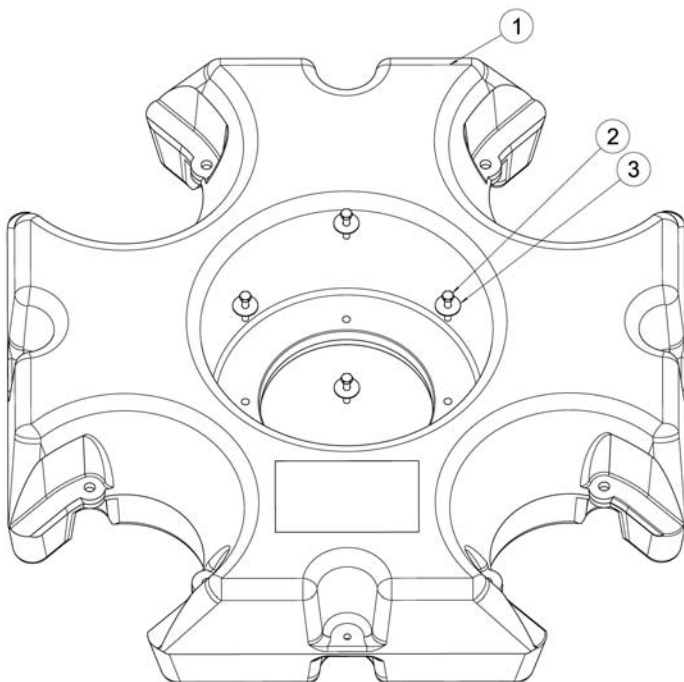

Fasten supplemental Float w/ Cable Ties

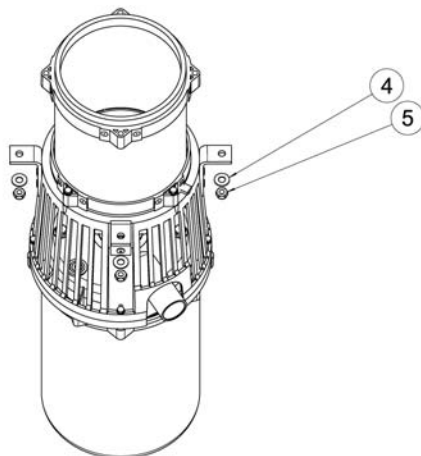

Parts List			
Item	Description	Part Number	Qty
1	Concept 3 Float	42-0018	1
	Float Mounting Hardware Kit (Below)	12-0071	1
2	M8x45 S/S Hex Bolt	22-0022	5
3	M8 Fender Washer	28-0008	5
4	M8 Flat Washer	28-0018	5
5	M8 Nylon Lock Nut	26-0007	5
6	Nylon Tie (Not Shown)	GP5008	3

C. Mounting the Stabilizers (Comet Spray Pattern Only)

1. Mount each of the four stabilizer plates to the top side of a bracket using a hex bolt, a fender washer, and a nylon locknut as shown below.
2. Mount each of the four stabilizer plate assemblies from Step C1 to the top side of an outer hole in the float using an eyebolt, a fender washer, and a nylon locknut as shown. **Do not** over tighten. Damage may occur to the float.

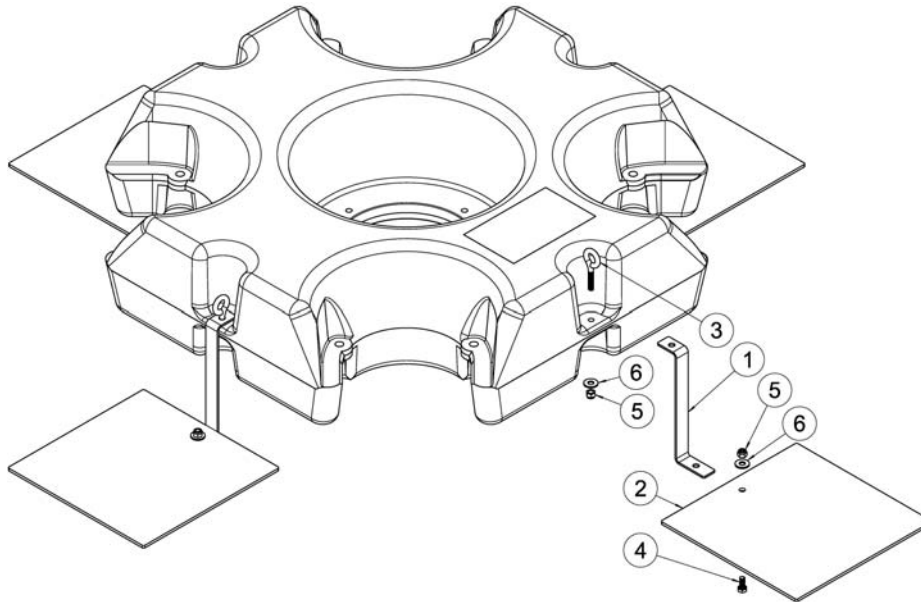

Parts List			
Item	Description	Part Number	Qty
	Comet Stabilizer Plates Kit	12-0097	
1	Stabilizer Bracket	40-0115	4
2	Stabilizer Plate	41-0127	4
3	5/16-18x1-3/8 S/S Eyebolt	22-0027	4
4	5/16-18x3/4" S/S Hex Bolt	106-302	4
5	5/16-18 S/S Nylon Lock Nut	GP1208	8
6	5/16" Fender Washer	28-0008	8

D. Screen Installation

Debris Screens help to prevent clogging of the aerator and are available for all Otterbine aerators.

1. Place the unit upside down on blocks so the pump chamber does not get damaged.
2. Make sure the cable/s are running through the bushing in the screen.
3. Pull screen over motor unit until it reaches the lip on the float.
4. Fasten the screen to the lip on the float with the washers and screws provided so they are evenly spaced around the diameter.

Parts List			
Item	Description	Part Number	Qty
	1/4" Screen Kit	12-0075	1
	1/2" Screen Kit	12-0076	1
1	C3 Screen1		1
	1/4"	15-0022	
	1/2"	15-0023	
2	S/S Sheet Metal Screw	BP2803B	9
3	1" Fender Washer	800-011	9

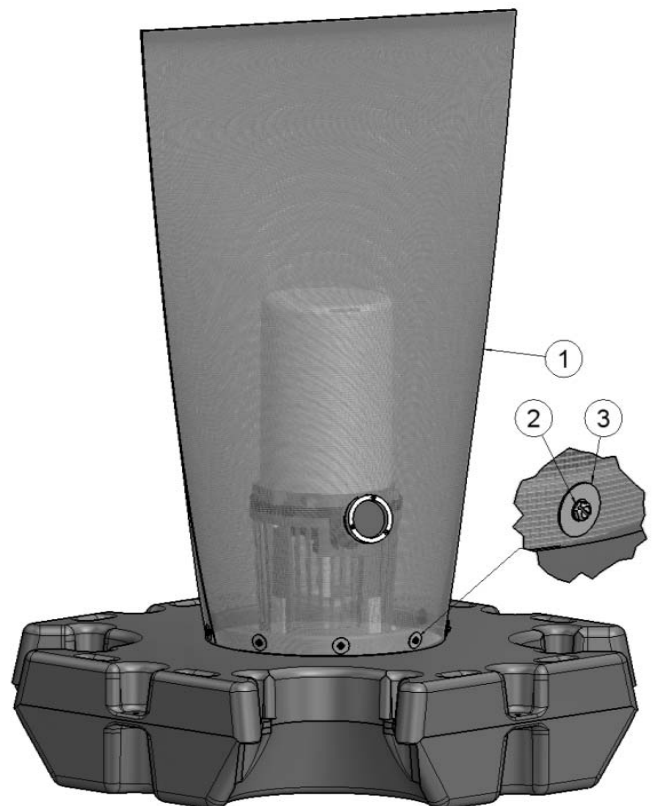

PHYSICAL INSTALLATION

WARNING: DISCONNECT POWER BEFORE INSTALLING, REMOVING, OR SERVICING UNIT

Concept 3 Otterbine aerators require a **minimum 30"/75cm (40"/100cm w/ lights)** of water depth.

A. Attach your Otterbine power cable to the aerator.

1. Align the keyway on the cable pigtail connector to the key on the aerator bulkhead connector and plug together. Thread the nut onto the bulkhead, hand tighten only, do not use tools on the pigtail connector nut.

Over tightening may cause the connector to fracture and possibly cause an electrical short circuit.

2. 5HP, 230V, 1 Phase units have a 3 pin bulkhead connector and a 3 pin pigtail connector on the power cable. All other ratings use 4 pin connectors.

3. A small amount of silicon compound has been factory applied to the female end of the aerator connector. The compound is necessary to make a waterproof seal between the two connectors. **DO NOT REMOVE COMPOUND!** When servicing the aerator re-apply compound. (Otterbine P/N: 48-0001).

4. **Install the cable strain relief device.** Pass the wire hoop from the strain relief through one of the holes in the float. Reattach wire hoop to strain relief (see above).

5. For additional protection fasten the power cable, after the strain relief, to a float hole using the cable ties provided.

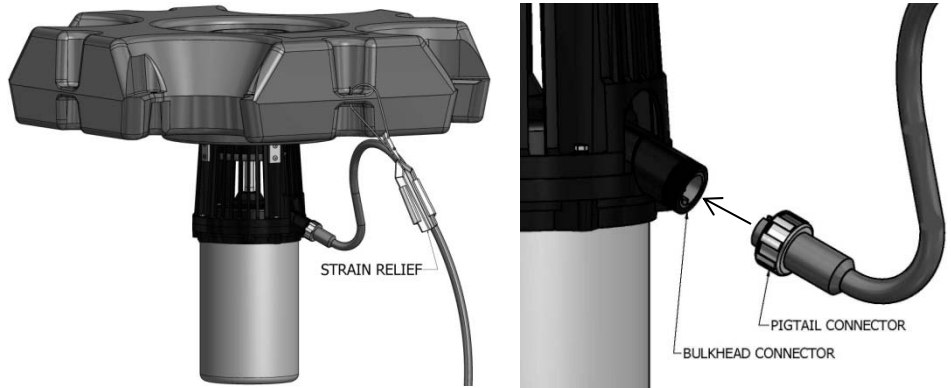

B. Pre-Startup Checks (To be performed by a qualified technician)

1. Factory connections may loosen during shipping. Verify tightness of all screw terminal connections before energizing.

2. Apply power to the PCC. Verify the incoming voltage is correct at the input terminals and matches the nameplate rating of the aerator. **For 115V & 230V Single Phase & Three Phase Units: The voltage between L1 on the input terminal block and the neutral terminal must measure a nominal 120V.**

3. With the main door open, the cover panel in place, and the H-O-A switch in the "OFF" position, follow GFCI instructions on page 11 to reset aerator GFCI. Turn on disconnect and proceed.

4. (3 Phase Units Only) With the aerator unit on the shore check for correct motor rotation. Briefly "bump" the H-O-A switch (Shown on Page 7) to "HAND" while observing the motor shaft rotation (turn on only long enough to establish operation and proper direction of rotation). **Aerator Shaft rotation MUST BE CCW looking at the top/impeller end of the unit.**

!TURN OFF DISCONNECT BEFORE PROCEEDING!

C. Fasten Mooring Lines and Launch

1. Mooring using stakes: Shore mounted stakes provides the easiest access to the aerator. Use stainless steel and/or brass hardware. Otterbine recommends using 1/4"(0.63cm) or 1/2"(1.25cm) polypropylene rope or stainless steel cable for mooring lines. At the mooring points use a wooden or metal stake or duck bill type earth anchors. Earth anchors allow the mooring lines to be hidden beneath the water surface. Drive the mooring stakes securely into the ground at the edge of the pond or place earth anchors close to the shore in the water. Fasten the mooring lines to opposite outer holes in the aerator float. Launch the aerator into the water, pull into the chosen location and fasten the lines to the stakes allowing slack for the aerator to twist up to 1/4 turn. The slack in the lines allows for movement during start up, fluctuations in the water level and wave action. Proceed to System Startup.

2. Mooring using Anchors: Use stainless steel and/or brass hardware. Otterbine recommends using 1/4"(0.63cm) or 1/2"(1.25cm) polypropylene rope or stainless steel cable for anchoring lines. Use two 60 - 80 lb. (27 - 36 kilo) weights for anchors. A boat may be needed. Fasten the mooring lines to opposite outer holes in the float. Launch the aerator floating upside down (motor housing facing up). With the lines attached drop the anchors into the water at the predetermined locations. Adjust the lines to allow slack for the aerator up to 1/4 turn twist. The slack in the lines allows for movement during start up, fluctuations in the water level and wave action. Flip unit back over motor end down.

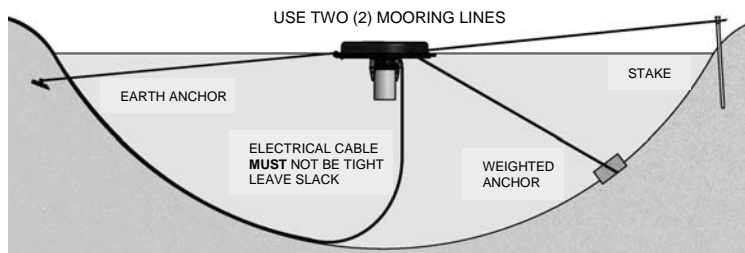

SYSTEM STARTUP

DO NOT ALLOW THE AERATOR TO OPERATE “DRY” OUT OF THE WATER

IMPORTANT: Otterbine aerators are designed to run in a Counterclockwise direction facing the top impeller end.

Current unbalance for three phase systems shall not exceed 5%.

IMPORTANT: Aérateurs Otterbine sont conçus pour fonctionner dans le sens antihoraire regardant l'extrémité supérieure de la turbine. Courant de déséquilibre pour les trois systèmes de la phase ne doit pas dépasser 5%

A. User Control Functions

1. Disconnect Switch

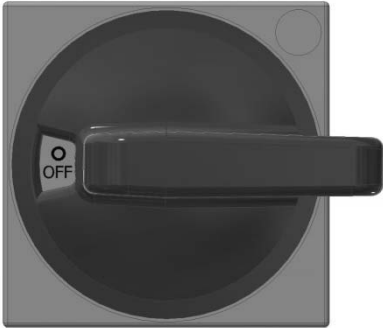

Disconnect Off – Single & 3 Phase

Removes Power to the Aerator for Maintenance/Service/Repair, Timers are not Powered



Disconnect On – Single & 3 Phase

Power Applied, Operation Depends on Position of HOA Switch, Timers are Powered



Disconnect Tripped – Single Phase Only

Indicates a ground fault trip or circuit breaker overcurrent

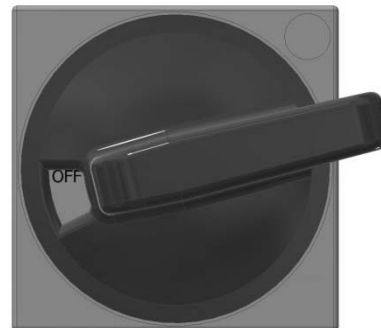

Disconnect Reset – Single Phase Only

Moving the handle slightly past the off position will reengage the circuit breaker and allow the breaker to be turned on.

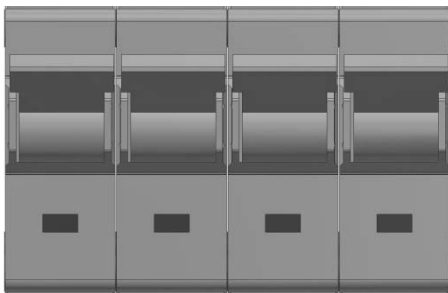

Breaker On (Handle Up) – 3 Phase Only

Main circuit breaker is on and aerator is ready to operate. Disconnect must also be on.

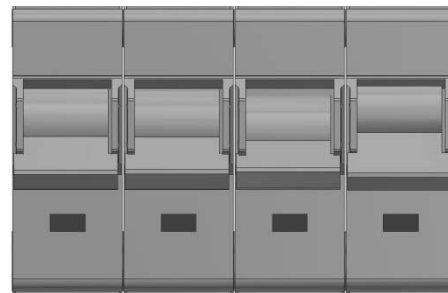

Breaker Off/Tripped (Handle Down) – 3 Phase Only

Indicates a ground fault trip or circuit breaker overcurrent

2. HAND-OFF-AUTO switch.

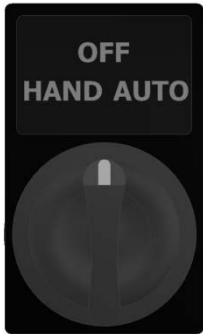

H-O-A IN OFF
Aerator & Lighting
Will Not Function,
Timers are
Powered and
Operating,
GFCI's may be
Reset

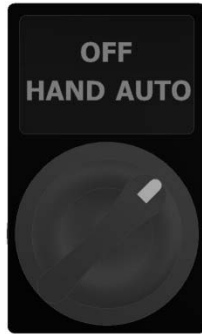

H-O-A IN AUTO
Allows Automatic
Control of Aerator
& Lighting by
Timers & Other
Control Options



H-O-A IN HAND
Turns on Aerator,
Bypasses Timer
& Non-Critical
Control Functions

3. Aerator Ground Fault Protection – Single Phase.

- a. Ground fault protection is built into the Square D circuit breaker.
- b. Ground fault protection is enabled whenever the circuit breaker is on.
- c. The ground fault protection should be periodically tested (Every 6 months) by pressing the yellow test button and verifying the circuit breaker turns off. Panel must be powered but aerator doesn't need to be on to test ground fault protection.

4. Aerator Ground Fault Protection – 3 Phase

- a. 3 phase panels utilize an Eaton current sensor and a shunt trip circuit breaker to provide protection.
- b. Ground fault protection is enabled whenever the green power indicator on the current sensor is lit. The indication is visible with the enclosure door open through a hole in the cover panel. If the indicator is not lit when the panel is powered (disconnect & breaker on), ground fault protection is not working and the panel should be repaired before using.
- c. The ground fault protection should be periodically tested (Every 6 months) by pressing the yellow test button and verifying the circuit breaker turns off. Disconnect and circuit breaker should be on but the aerator doesn't need to be running.

5. Lighting ground fault protection

- a. The same device(s) used to provide ground fault protection for the aerator is also used to protect the lighting circuits.

6. Timer Operation

- a. Setting the Clock - Press and hold the "CLOCK" key. Press the "DAY" key to display the correct day. Do the same with the "HOUR" and "MIN" keys.
- b. Setting the Timer - Press the "DAY" key to select one of the 15 daily programs. Then press the "TIMER" key to display "1 ON" and set the turn on time by pressing the "HOUR" and "MIN" keys. To set the turn off time press the "TIMER" key again to display "1 OFF". Then again set the hour and minutes. Repeat this process for up to 8 on/off cycles per day.
- c. To enable the timer press the "MANUAL" key until the line is above "AUTO".
- d. Refer to timer instructions supplied for more detailed operation.



B. Energizing the Unit (To be performed by a qualified technician)

1. Single Phase Units: Motor rotation is factory determined and not field adjustable.
2. Three Phase Units: Verify correct motor rotation (Counter Clockwise looking at the top/impeller end of the unit). Check current readings on each phase. Verify three phase operating currents are balanced within 5%.
To calculate the percent of current unbalance:

Determine the Average Current:

- a. Measure each of the three phase currents
- b. Add the three phase amperage values together.
- c. Divide the sum by three.
- d. This is the average current value.

Determine Current Unbalance:

- a. Select the phase current with the greatest difference from the average (calculated above).
- b. Determine the difference between this phase current and the average current value.
- c. Divide the difference by the average.
- d. Multiply the result by 100 to determine percent of unbalance.

3. Use connection diagram 1, 2 or 3 at right which results in the lowest current unbalance. Roll the motor cable leads on the aerator output terminal block in the same direction to avoid motor reversal. If the current unbalance is not corrected by rolling leads, locate the source of the unbalance and correct it.

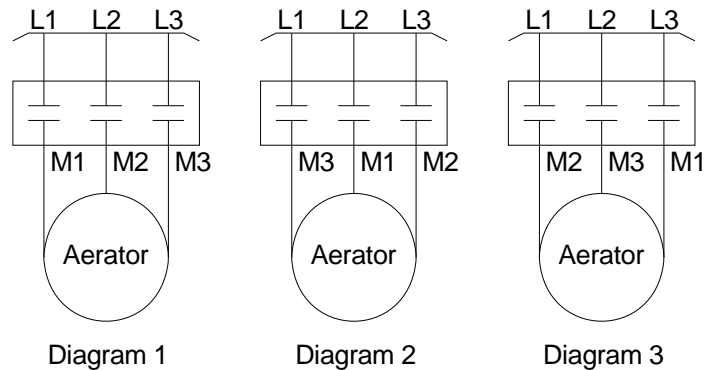

a. If the phase farthest from the average current stays on the same power lead after being moved the primary cause of unbalance is the power source.

b. If the phase farthest from the average current moves on each of the connections with a particular motor lead, then the primary cause of unbalance is on the "motor side" of the circuit.

Consider: damaged cable, leaking splice, poor connection, or a faulty motor as possible causes.

4. Once the unit is operational record the operating voltage, amperage, power control center serial number, power cable length and cable gauge on the label inside the power control panel.

MAINTENANCE

For Warranty Consideration Work Must Be Performed By an Authorized Service Facility

- A. Keep the pumping chamber components and screen free of debris. Damage can occur to a clogged aerator.
- B. Once a year, disconnect the unit from the power source and physically inspect the aerator, float and electrical cable. Visible damage to the motor unit or cable should be repaired to avoid safety hazards and/or potential failure.
- C. Every three years, an oil change using "Otterbine Oil" is recommended to keep your aerator operating smoothly.

When a unit is properly cared for, it will give you years of trouble free service.

For Service, Repairs or Parts, Contact Your Local Otterbine Distributor

or

Call Otterbine Directly at 1-800-237-8837.

WINTERIZATION

Damage caused to the motor due to freezing will not be covered under warranty

In locations with extended periods of freezing temperatures the aerator may become frozen into the water possibly causing damage. Otterbine recommends the following Concept 3 units be removed from the water during freezing temperatures: ROCKET, PHOENIX, TRI-STAR, CONSTELLATION, COMET, GENESIS, EQUINOX, and OMEGA. The GEMINI, SATURN, and SUNBURST pump higher volumes of water which helps to keep the water around the aerator from freezing. 24 hour a day operation will further decrease the opportunity for the unit to freeze in, although during periods of extremely cold temperatures this will not prevent the water from freezing. Operating temperature range is -12°C to 40°C (10°F to 104°F).

SUNBURST PUMP CHAMBER

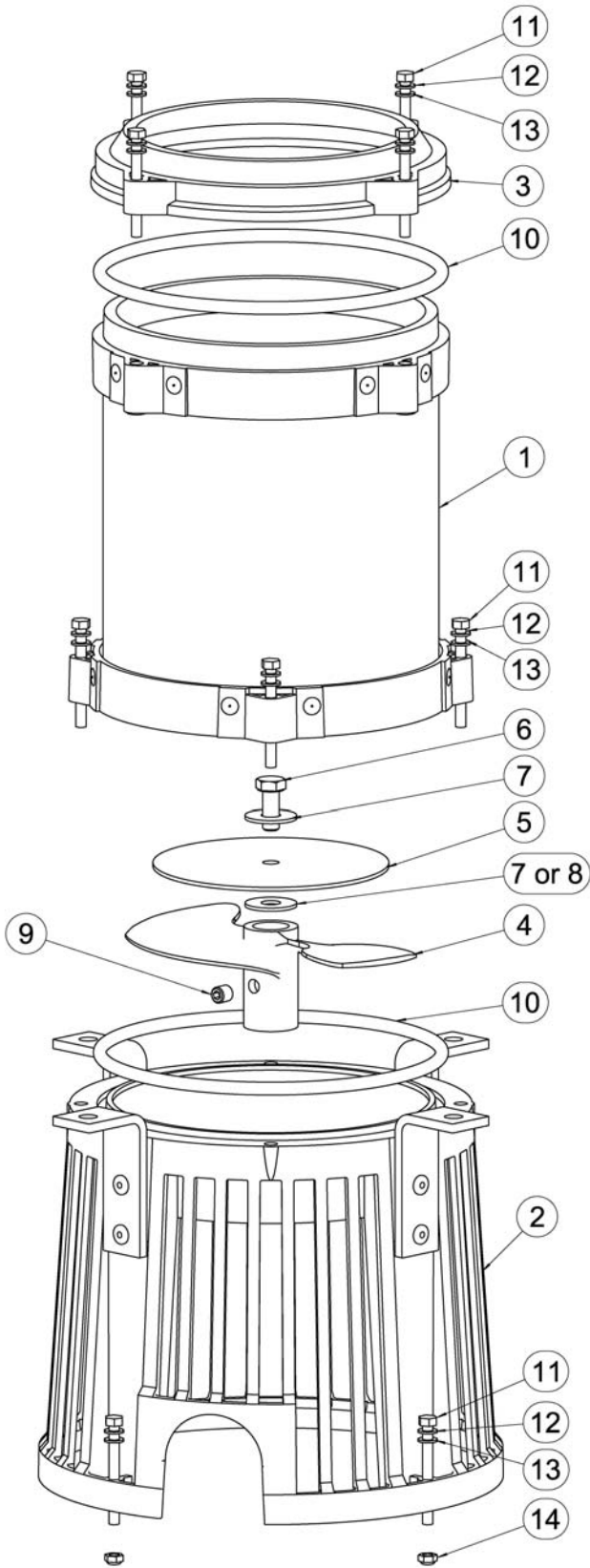

Parts List			
Item	Description	Part Number	Qty
1	Throat Assembly	10-0060	1
2	Standoff Strainer Assembly	10-0061	1
3	Sunburst Ring	75-0019	1
4	Sunburst Impeller		1
	1HP, 60Hz	50-0012-001	
	2HP, 60Hz	50-0012-002	
	3HP, 60Hz	50-0012-003	
	5HP, 60Hz	50-0012-005	
5	Slinger Disc	47-0003	1
6	M8x20 S/S Hex Bolt	22-0019	1
7	M8 (5/16") S/S Fender Washer (3HP Spacer)	28-0008	1
8	M8 (5/16") S/S Fender Washer (5HP Spacer)	40-0107	1
9	M8x8 S/S Set Screw	24-0015	1
10	O-Ring #260	49-0015	2
11	M5x50 S/S Hex Bolt	24-0013	12
12	M5 S/S Split Lock Washer	28-0017	12
13	M5 S/S Flat Washer	28-0016	12
14	M5 S/S Nylon Locknut	26-0006	4

Sunburst Assembly Instructions

- Slide the Impeller onto the motor shaft so the top of the hub is even with the top of the shaft. Tighten the set screw onto one of the flats on the shaft.
- Mount the Slinger Disc to the shaft using (1) M8x20 S/S Hex Bolt and (1) M8 S/S Fender Washer. An Impeller Spacer is ONLY used with 3HP 60Hz/2HP 50Hz, 5HP 60Hz/3HP 50Hz, and 5HP 50Hz impellers (Item No. 7 or 8). Tighten the bolt to 35 ft-lbs (47 N-m).
- Mount the Standoff Strainer Assembly to the power unit using (4) M5x50 S/S Hex Screws, (4) M5 S/S Flat Washers, (4) M5 S/S Split Lock Washers, and (4) M5 S/S Hex Nylon Locknuts. Tighten the screws evenly. **NOTE:** Standoff Strainer Assembly is not part of the Pump Chamber Assembly.
- Place an O-ring in the groove on the top of the Standoff Strainer Assembly.
- Mount the Throat Assembly to the Standoff Strainer Assembly using (4) M5x50 S/S Hex Screws, (4) M5 S/S Flat Washers, and (4) M5 S/S Split Lock Washers. Tighten the screws evenly in order to properly compress the o-ring.
- Place an O-ring on the top of the Throat Assembly.
- Mount the Sunburst Ring to the Throat Assembly using (4) M5x50 S/S Hex Screws, (4) M5 S/S Flat Washers, and (4) M5 S/S Split Lock Washers. Tighten the screws evenly in order to properly compress the o-ring.

GEMINI PUMP CHAMBER

Parts List			
Item	Description	Part Number	Qty
1	Throat Assembly	10-0060	1
2	Standoff Strainer Assembly	10-0061	1
4	Sunburst Impeller 1HP, 60Hz 2HP, 60Hz 3HP, 60Hz 5HP, 60Hz	50-0012-001 50-0012-002 50-0012-003 50-0012-005	1
5	Slinger Disc	47-0003	1
6	M8x20 S/S Hex Bolt	22-0019	1
7	M8 (5/16") S/S Fender Washer (3HP Spacer)	28-0008	1
8	M8 (5/16") S/S Fender Washer (5HP Spacer)	40-0107	1
9	M8x8 S/S Set Screw	24-0015	1
10	O-Ring #260	49-0015	1
11	M5x50 S/S Hex Bolt	24-0013	8
12	M5 S/S Split Lock Washer	28-0017	8
13	M5 S/S Flat Washer	28-0016	8
14	M5 S/S Nylon Locknut	26-0006	4

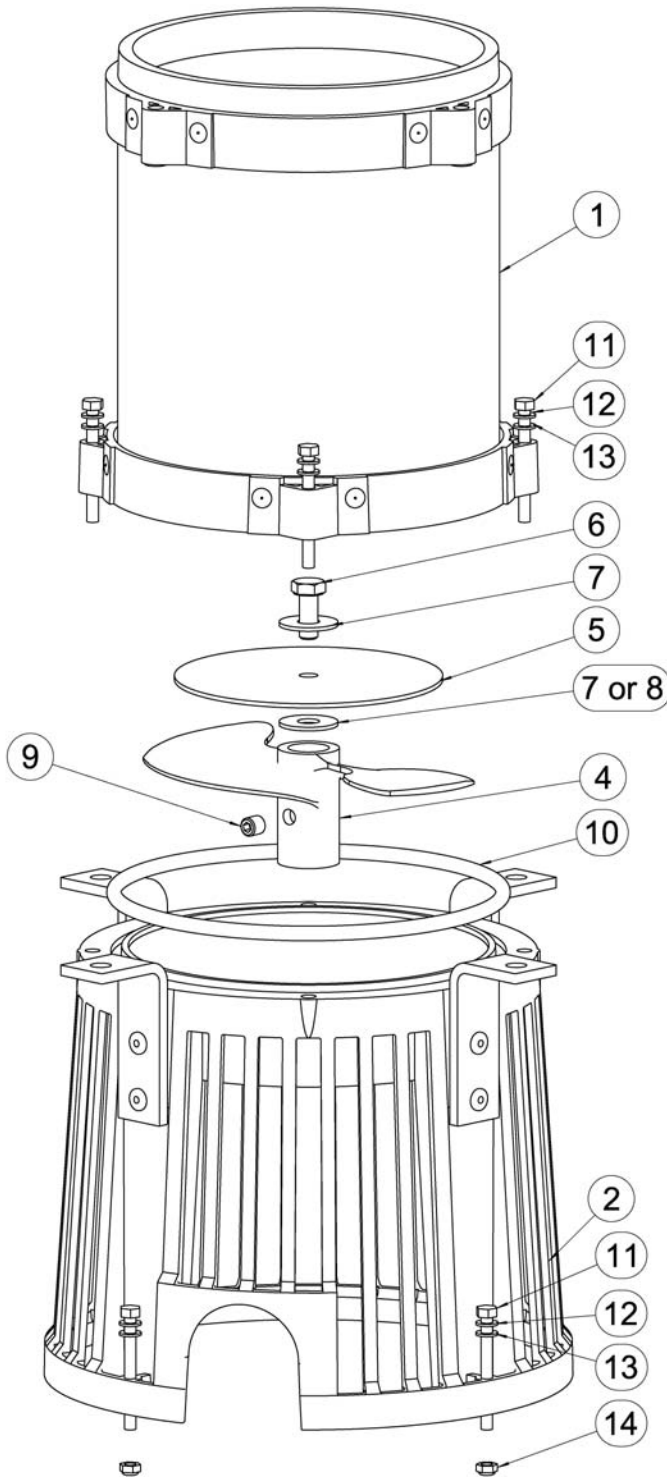

Gemini Assembly Instructions

1. Slide the Impeller onto the motor shaft so the top of the hub is even with the top of the shaft. Tighten the set screw onto one of the flats on the shaft.
2. Mount the Slinger Disc to the shaft using (1) M8x20 S/S Hex Bolt and (1) M8 S/S Fender Washer. An Impeller Spacer is ONLY used with 3HP 60Hz/2HP 50Hz, 5HP 60Hz/3HP 50Hz, and 5HP 50Hz impellers (Item No. 7 or 8). Tighten the bolt to 35 ft-lbs (47 N-m).
3. Mount the Standoff Strainer Assembly to the power unit using (4) M5x50 S/S Hex Screws, (4) M5 S/S Flat Washers, (4) M5 S/S Split Lock Washers, and (4) M5 S/S Hex Nylon Locknuts. Tighten the screws evenly. NOTE: Standoff Strainer Assembly is not part of the Pump Chamber Assembly.
4. Place an O-ring in the groove on the top of the Standoff Strainer Assembly.
5. Mount the Throat Assembly to the Standoff Strainer Assembly using (4) M5x50 S/S Hex Screws, (4) M5 S/S Flat Washers, and (4) M5 S/S Split Lock Washers. Tighten the screws evenly in order to properly compress the o-ring.

SATURN PUMP CHAMBER

Parts List			
Item	Description	Part Number	Qty
1	Throat Assembly	10-0060	1
2	Standoff Strainer Assembly	10-0061	1
3	Sunburst Ring	42-0019	1
4	Sunburst Impeller 1HP, 60Hz 2HP, 60Hz 3HP, 60Hz 5HP, 60Hz	50-0012-001 50-0012-002 50-0012-003 50-0012-005	1
5	Slinger Disc	47-0003	1
9	M8x8 S/S Set Screw	24-0015	1
10	O-Ring #260	49-0015	2
11	M5x50 S/S Hex Bolt	24-0013	12
12	M5 S/S Split Lock Washer	28-0017	12
13	M5 S/S Flat Washer	28-0016	12
14	M5 S/S Nylon Locknut	26-0006	4

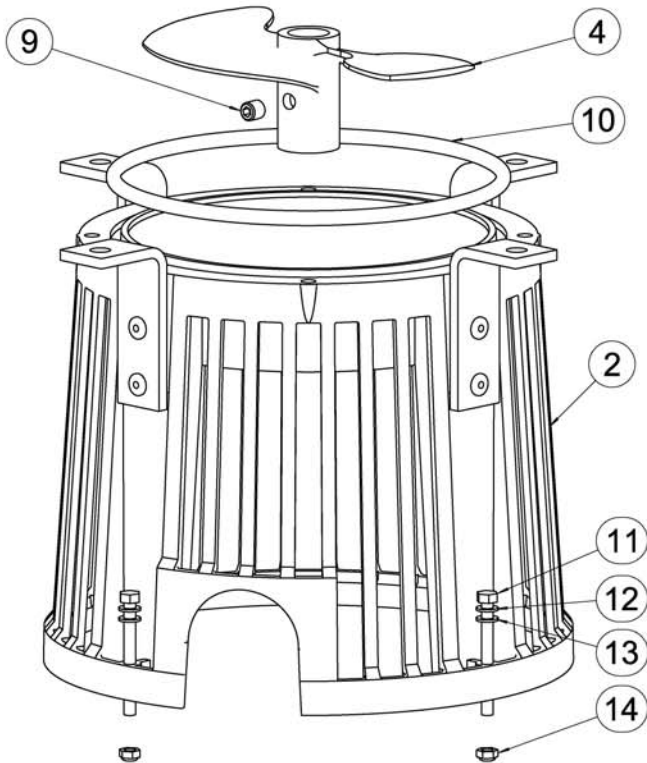
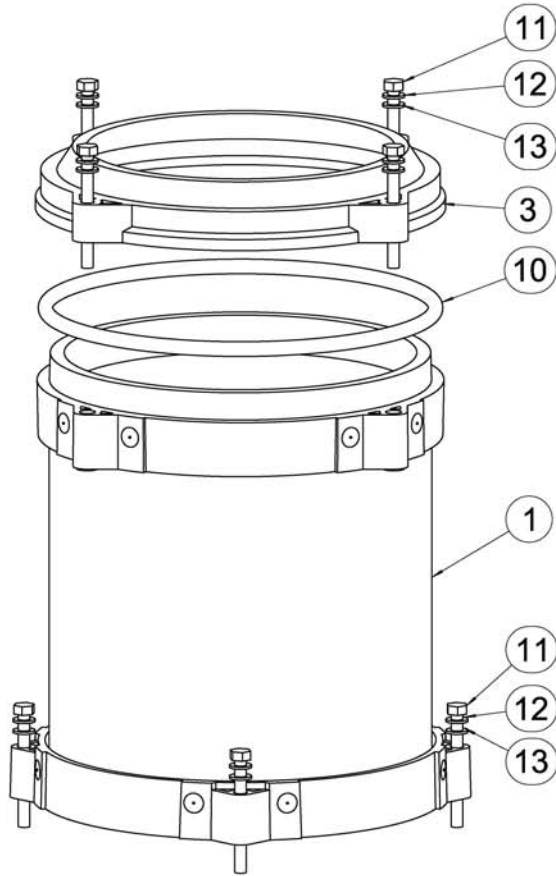

Saturn Assembly Instructions

1. Slide the Impeller onto the motor shaft so the top of the hub is even with the top of the shaft. Tighten the set screw onto one of the flats on the shaft.
2. Place an O-ring in the groove on the top of the Standoff Strainer Assembly.
3. Mount the Standoff Strainer Assembly to the power unit using (4) M5x50 S/S Hex Screws, (4) M5 S/S Flat Washers, (4) M5 S/S Split Lock Washers, and (4) M5 S/S Hex Nylon Locknuts. Tighten the screws evenly. **NOTE:** Standoff Strainer Assembly is not part of the Pump Chamber Assembly.
4. Mount the Throat Assembly to the Standoff Strainer Assembly using (4) M5x50 S/S Hex Screws, (4) M5 S/S Flat Washers, and (4) M5 S/S Split Lock Washers. Tighten the screws evenly in order to properly compress the o-ring.
5. Place an O-ring on the top of the Throat Assembly.
6. Mount the Sunburst Ring to the Throat Assembly using (4) M5x50 S/S Hex Screws, (4) M5 S/S Flat Washers, and (4) M5 S/S Split Lock Washers. Tighten the screws evenly in order to properly compress the o-ring.

ROCKET PUMP CHAMBER

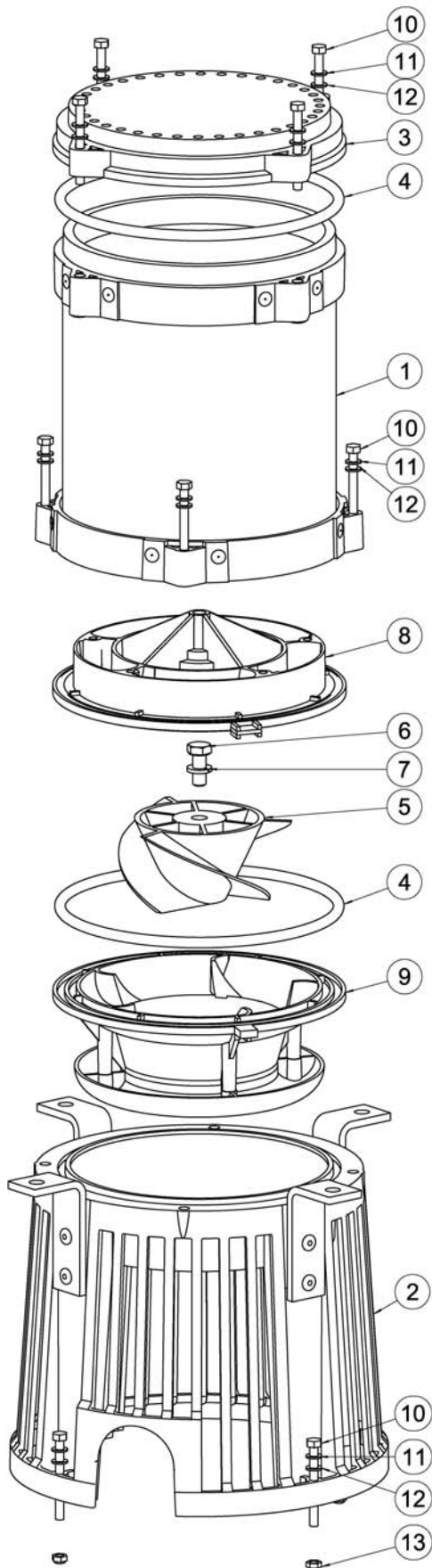

Parts List			
Item	Description	Part Number	Qty
1	Throat Assembly	10-0060	1
2	Standoff Strainer Assembly	10-0061	1
3	Rocket Diffuser	41-0104	1
4	O-Ring #260	49-0015	3
5	Decorative Impeller 1HP, 60Hz 2HP, 60Hz 3HP, 60Hz 5HP, 60Hz	50-0010-001 50-0010-002 50-0010-003 50-0010-005	1
6	M8x20 S/S Hex Bolt	22-0019	1
7	M8 (5/16'') S/S Split Lock Washer	28-0019	1
8	Upper Pump Chamber	42-0023	1
9	Lower Pump Chamber Assembly	10-0065	1
10	M5x50 S/S Hex Bolt	24-0013	12
11	M5 S/S Split Lock Washer	28-0017	12
12	M5 S/S Flat Washer	28-0016	12
13	M5 S/S Nylon Locknut	26-0006	4
14	Decorative Impeller Shim (not shown)	40-0099	1,2,3, or 4

Rocket Assembly Instructions

1. Mount the Standoff Strainer Assembly to the power unit using (4) M5x50 S/S Hex Screws, (4) M5 S/S Flat Washers, (4) M5 S/S Split Lock Washers, and (4) M5 S/S Hex Nylon Locknuts. Tighten the screws evenly. **NOTE:** Standoff Strainer Assembly is not part of the Pump Chamber Assembly.
2. Place the Lower Pump Chamber Assembly into the Standoff Strainer Assembly.
3. Slide the Impeller onto the motor shaft. If the Impeller rubs against the inside wall of the Lower Pump Chamber Assembly place 1, 2, 3, or 4 (Item 14) Shims as necessary onto the end of the shaft to raise the Impeller so it no longer rubs. Secure using (1) M8x20 S/S Hex Bolt and (1) M8 S/S Split Lock Washer. Tighten the bolt.
4. Place an O-ring in the groove of the Lower Pump Chamber.
5. Place the Upper Pump Chamber onto the Lower Pump Chamber Assembly so the tabs on each part align. **NOTE:** If these tabs do not align the pump will not function properly.
6. Place an O-ring in the groove of the Upper Pump Chamber.
7. Place the Throat Assembly onto the Upper Pump Chamber and secure using (4) M5x50 S/S Hex Screws, (4) M5 S/S Flat Washers, and (4) M5 S/S Split Lock Washers. Tighten the screws evenly in order to properly compress the o-rings.
8. Place an O-ring on the top of the Throat Assembly.
9. Mount the Rocket Diffuser to the Throat Assembly using (4) M5x50 S/S Hex Screws, (4) M5 S/S Flat Washers, and (4) M5 S/S Split Lock Washers. Tighten the screws evenly in order to properly compress the o-ring.

PHOENIX PUMP CHAMBER

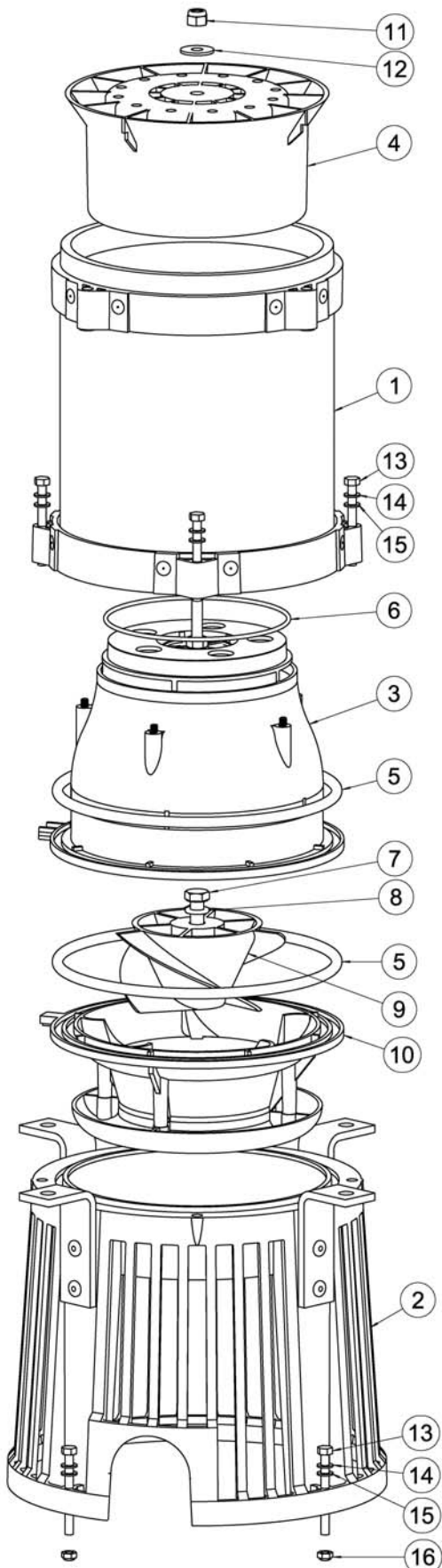

Parts List			
Item	Description	Part Number	Qty
1	Throat Assembly	10-0060	1
2	Standoff Strainer Assembly	10-0061	1
3	Phoenix/Tri-Star Flow Diverter	10-0062	1
4	Phoenix Diffuser	41-0105	1
5	O-Ring #260	49-0015	2
6	O-Ring #156	49-0018	1
7	M8x20 S/S Hex Bolt	22-0019	1
8	M8 (5/16") S/S Split Lock Washer	28-0019	1
9	Decorative Impeller 1HP, 60Hz 2HP, 60Hz 3HP, 60Hz 5HP, 60Hz	50-0010-001 50-0010-002 50-0010-003 50-0010-005	1
10	Lower Pump Chamber	10-0065	1
11	M8 S/S Nylon Locknut	26-0007	1
12	M8 (5/16") S/S Flat Washer	28-0018	1
13	M5x50 S/S Hex Bolt	24-0013	8
14	M5 S/S Split Lock Washer	28-0017	8
15	M5 S/S Flat Washer	28-0016	8
16	M5 S/S Nylon Locknut	26-0006	4
17	Decorative Impeller Shim (not shown)	40-0099	1,2,3, or 4

Phoenix Assembly Instructions

1. Mount the Standoff Strainer Assembly to the power unit using (4) M5x50 S/S Hex Screws, (4) M5 S/S Flat Washers, (4) M5 S/S Split Lock Washers, and (4) M5 S/S Hex Nylon Locknuts. Tighten the screws evenly. **NOTE:** Standoff Strainer Assembly is not part of the Pump Chamber Assembly.
2. Place the Lower Pump Chamber Assembly into the Standoff Strainer Assembly.
3. Slide the Impeller onto the motor shaft. If the Impeller rubs against the inside wall of the Lower Pump Chamber Assembly place 1, 2, 3, or 4 Shims (Item 17) as necessary onto the shaft to raise the Impeller so it no longer rubs. Secure using (1) M8x20 S/S Hex Bolt and (1) M8 S/S Split Lock Washer. Tighten the bolt.
4. Place an O-ring in the groove of the Lower Pump Chamber.
5. Place the Phoenix/Tri-Star Flow Diverter Assembly onto the Lower Pump Chamber Assembly so the tabs on each part align. **NOTE:** If these tabs do not align the pump will not function properly.
6. Place an O-ring in the groove of the Upper Pump Chamber.
7. Place the Throat Assembly onto the Upper Pump Chamber and secure using (4) M5x50 S/S Hex Screws, (4) M5 S/S Flat Washers, and (4) M5 S/S Split Lock Washers. Tighten the screws evenly in order to properly compress the o-ring.
8. Place an O-ring on the top of the Flow Diverter.
9. Slide the Phoenix Diffuser onto the Carriage Bolt until seated on the Flow Diverter Assembly and secure using a M8 S/S Flat Washer and a M8 S/S Nylon Locknut. Center the Diffuser on the Throat Assembly, tighten the locknut (11). Do not over tighten, may cause damage.

TRI-STAR PUMP CHAMBER

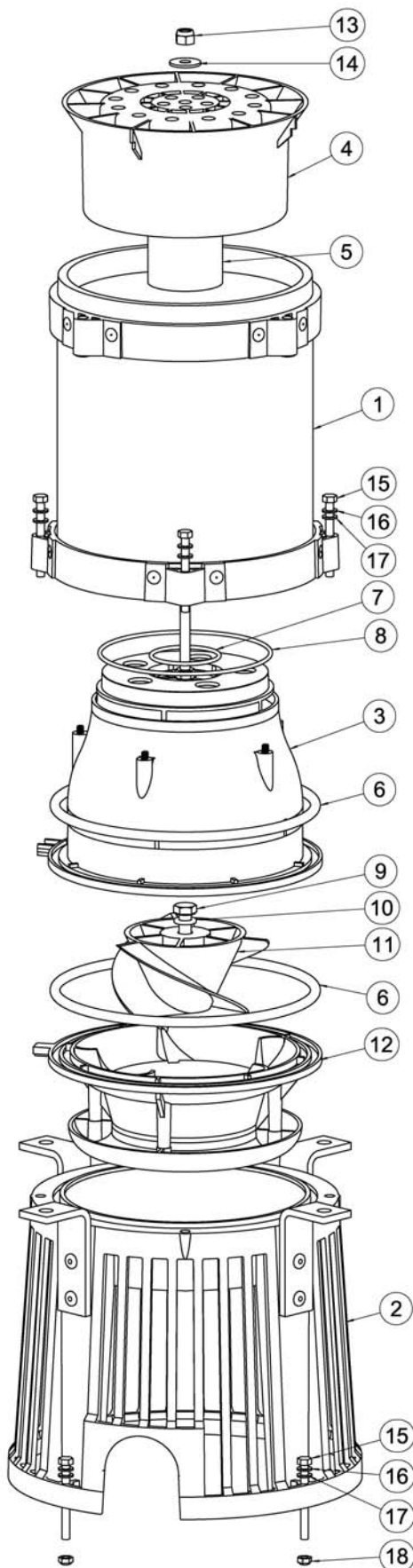

Parts List			
Item	Description	Part Number	Qty
1	Throat Assembly	10-0060	1
2	Standoff Strainer Assembly	10-0061	1
3	Phoenix/Tri-Star Flow Diverter	10-0062	1
4	Tri-Star Diffuser	41-0106	1
5	Tri-Star Diffuser Pipe	41-0108	1
6	O-Ring #260	49-0015	2
7	O-Ring #131	49-0015	2
8	O-Ring #156	49-0018	1
9	M8x20 S/S Hex Bolt	22-0019	1
10	M8 (5/16") S/S Split Washer	28-0019	1
11	Decorative Impeller 1HP, 60Hz 2HP, 60Hz 3HP, 60Hz 5HP, 60Hz	50-0010-001 50-0010-002 50-0010-003 50-0010-005	1
12	Lower Pump Chamber	10-0065	1
13	M8 S/S Nylon Locknut	26-0007	1
14	M8 (5/16") S/S Flat Washer	28-0018	1
15	M5x50 S/S Hex Bolt	24-0013	8
16	M5 S/S Split Lock Washer	28-0017	8
17	M5 S/S Flat Washer	28-0016	8
18	M5 S/S Nylon Locknut	26-0006	4
19	Decorative Impeller Shim (not shown)	40-0099	1,2,3, or 4

Tri-Star Assembly Instructions

1. Mount the Standoff Strainer Assembly to the power unit using (4) M5x50 S/S Hex Screws, (4) M5 S/S Flat Washers, (4) M5 S/S Split Lock Washers, and (4) M5 S/S Hex Nylon Locknuts. Tighten the screws evenly. **NOTE:** Standoff Strainer Assembly is not part of the Pump Chamber Assembly.
2. Place the Lower Pump Chamber Assembly into the Standoff Strainer Assembly.
3. Slide the Impeller onto the motor shaft. If the Impeller rubs against the inside wall of the Lower Pump Chamber Assembly place 1, 2, 3 or 4 Shims (Item 19) as necessary onto the shaft to raise the Impeller so it no longer rubs. Secure using (1) M8x20 S/S Hex Bolt and (1) M8 S/S Split Lock Washer. Tighten the bolt.
4. Place an O-ring in the groove of the Lower Pump Chamber.
5. Place the Phoenix/Tri-Star Flow Diverter Assembly onto the Lower Pump Chamber Assembly so the tabs on each part align. **NOTE:** If these tabs do not align the pump will not function properly.
6. Place an O-ring in the groove of the Upper Pump Chamber.
7. Place the Throat Assembly onto the Upper Pump Chamber and secure using (4) M5x50 S/S Hex Screws, (4) M5 S/S Flat Washers, and (4) M5 S/S Split Lock Washers. Tighten the screws evenly in order to properly compress the o-rings.
8. Place two (2) o-rings on the top inside & outside of the Flow Diverter.
9. Place the Tri-Star Diffuser Pipe in the Flow Diverter Assembly so it rests on the O-ring.
10. Slide the Tri-Star Diffuser onto the Carriage Bolt until seated on the Flow Diverter Assembly/Tri-Star Diffuser Pipe, secure using an M8 S/S Flat Washer and an M8 S/S Nylon Locknut. Center the Diffuser on the Throat Assembly, tighten the locknut (13). Do not over tighten, may cause damage. CONSTELLATION PUMP CHAMBER

CONSTELLATION PUMP CHAMBER

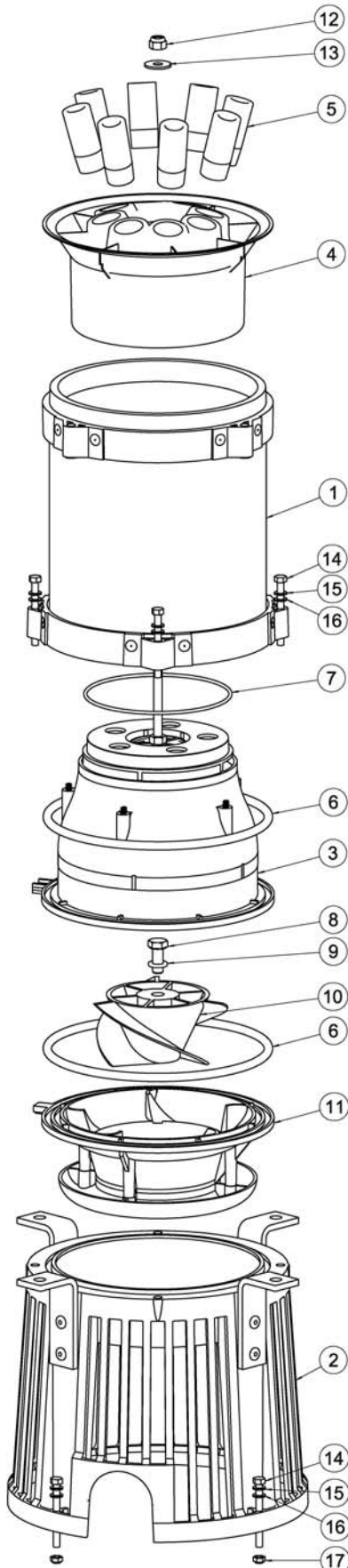

Parts List			
Item	Description	Part Number	Qty
1	Throat Assembly	10-0060	1
2	Standoff Strainer Assembly	10-0061	1
3	Constellation Flow Diverter	10-0069	1
4	Constellation Diffuser	42-0032	1
5	Constellation Nozzle Assembly	10-0068	1
6	O-Ring #260	49-0015	2
7	O-Ring #156	49-0018	1
8	M8x20 S/S Hex Bolt	22-0019	1
9	M8 (5/16'') S/S Split Washer	28-0019	1
10	Decorative Impeller 1HP, 60Hz 2HP, 60Hz 3HP, 60Hz 5HP, 60Hz	50-0010-001 50-0010-002 50-0010-003 50-0010-005	1
11	Lower Pump Chamber	10-0065	1
12	M8 S/S Nylon Locknut	26-0007	1
13	M8 (5/16'') S/S Flat Washer	28-0018	1
14	M5x50 S/S Hex Bolt	24-0013	8
15	M5 S/S Split Lock Washer	28-0017	8
16	M5 S/S Flat Washer	28-0016	8
17	M5 S/S Nylon Locknut	26-0006	4
18	Decorative Impeller Shim (not shown)	40-0099	1,2,3, or 4

Constellation Assembly Instructions

1. Mount the Standoff Strainer Assembly to the power unit using (4) M5x50 S/S Hex Screws, (4) M5 S/S Flat Washers, (4) M5 S/S Split Lock Washers, and (4) M5 S/S Hex Nylon Locknuts. Tighten the screws evenly. **NOTE:** Standoff Strainer Assembly is not part of the Pump Chamber Assembly.
2. Place the Lower Pump Chamber Assembly into the Standoff Strainer Assembly.
3. Slide the Impeller onto the motor shaft. If the Impeller rubs against the inside wall of the Lower Pump Chamber Assembly place 1, 2, 3 or 4 Shims (Item 18) as necessary onto the shaft to raise the Impeller so it no longer rubs. Secure using (1) M8x20 S/S Hex Bolt and (1) M8 S/S Split Lock Washer. Tighten the bolt.
4. Place an O-ring in the groove of the Lower Pump Chamber.
5. Place the Constellation Flow Diverter Assembly onto the Lower Pump Chamber Assembly so the tabs on each part align. **NOTE:** If these tabs do not align the pump will not function properly.
6. Place an O-ring in the groove of the Upper Pump Chamber.
7. Place the Throat Assembly onto the Upper Pump Chamber and secure using (4) M5x50 S/S Hex Screws, (4) M5 S/S Flat Washers, and (4) M5 S/S Split Lock Washers. Tighten the screws evenly in order to properly compress the o-ring.
8. Place an O-ring on the top of the Flow Diverter Assembly.
9. Slide the Constellation Diffuser onto the Carriage Bolt until seated on the Flow Diverter Assembly. Secure using an M8 S/S Flat Washer and S/S Nylon Locknut. Center the Diffuser on the Throat Assembly. Tighten the locknut. Do not over tighten, may cause damage.
10. Thread a Constellation Nozzle into one of the holes in the Galaxy Diffuser and tighten (**DO NOT OVER TIGHTEN, MAY CAUSE DAMAGE**). Repeat for the remaining seven Galaxy Nozzles. **NOTE:** Place Teflon tape on the threads of the Constellation Nozzle.

COMET PUMP CHAMBER

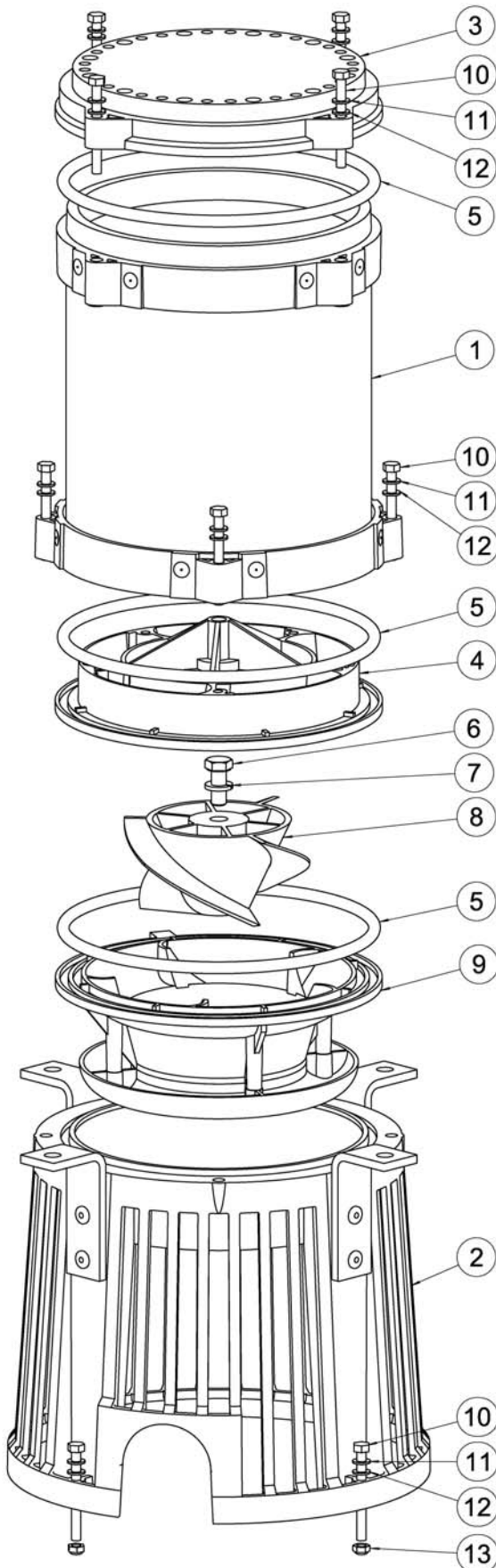

Parts List			
Item	Description	Part Number	Qty
1	Throat Assembly	10-0060	1
2	Standoff Strainer Assembly	10-0061	1
3	Comet Diffuser	41-0123	1
4	Upper Pump Chamber	42-0023	1
5	O-Ring #260	49-0015	3
6	M8x20 S/S Hex Bolt	22-0019	1
7	M8 (5/16") S/S Split Lock Washer	28-0019	1
8	Decorative Impeller 1HP, 60Hz 2HP, 60Hz 3HP, 60Hz 5HP, 60Hz	50-0010-001 50-0010-002 50-0010-003 50-0010-005	1
9	Lower Pump Chamber Assembly	10-0065	1
10	M5x50 S/S Hex Bolt	24-0013	12
11	M5 S/S Split Lock Washer	28-0017	12
12	M5 S/S Flat Washer	28-0016	12
13	M5 S/S Nylon Locknut	26-0006	4
14	Decorative Impeller Shim (not shown)	40-0099	1,2,3, or 4

Comet Assembly Instructions

1. Mount the Standoff Strainer Assembly to the power unit using (4) M5x50 S/S Hex Screws, (4) M5 S/S Flat Washers, (4) M5 S/S Split Lock Washers, and (4) M5 S/S Hex Nylon Locknuts. Tighten the screws evenly. **NOTE:** Standoff Strainer Assembly is not part of the Pump Chamber Assembly.
2. Place the Lower Pump Chamber Assembly into the Standoff Strainer Assembly.
3. Slide the Impeller onto the motor shaft. If the Impeller rubs against the inside wall of the Lower Pump Chamber Assembly place 1, 2, 3 or 4 Shims (Item 14) as necessary onto the shaft to raise the Impeller so it no longer rubs. Secure using (1) M8x20 S/S Hex Bolt and (1) M8 S/S Split Lock Washer. Tighten the bolt.
4. Place an O-ring in the groove of the Lower Pump Chamber.
5. Place the Upper Pump Chamber onto the Lower Pump Chamber Assembly so the tabs on each part align. **NOTE:** If these tabs do not align the pump will not function properly.
6. Place an O-ring in the groove of the Upper Pump Chamber.
7. Place the Throat Assembly onto the Upper Pump Chamber and secure using (4) M5x50 S/S Hex Screws, (4) M5 S/S Flat Washers, and (4) M5 S/S Split Lock Washers. Tighten the screws evenly in order to properly compress the o-ring.
8. Place an O-ring on the top of the Throat Assembly.
9. Mount the Comet Diffuser to the Throat Assembly using (4) M5x50 S/S Hex Screws, (4) M5 S/S Flat Washers, and (4) M5 S/S Split Lock Washers. Tighten the screws evenly in order to properly compress the o-ring.

GENESIS PUMP CHAMBER

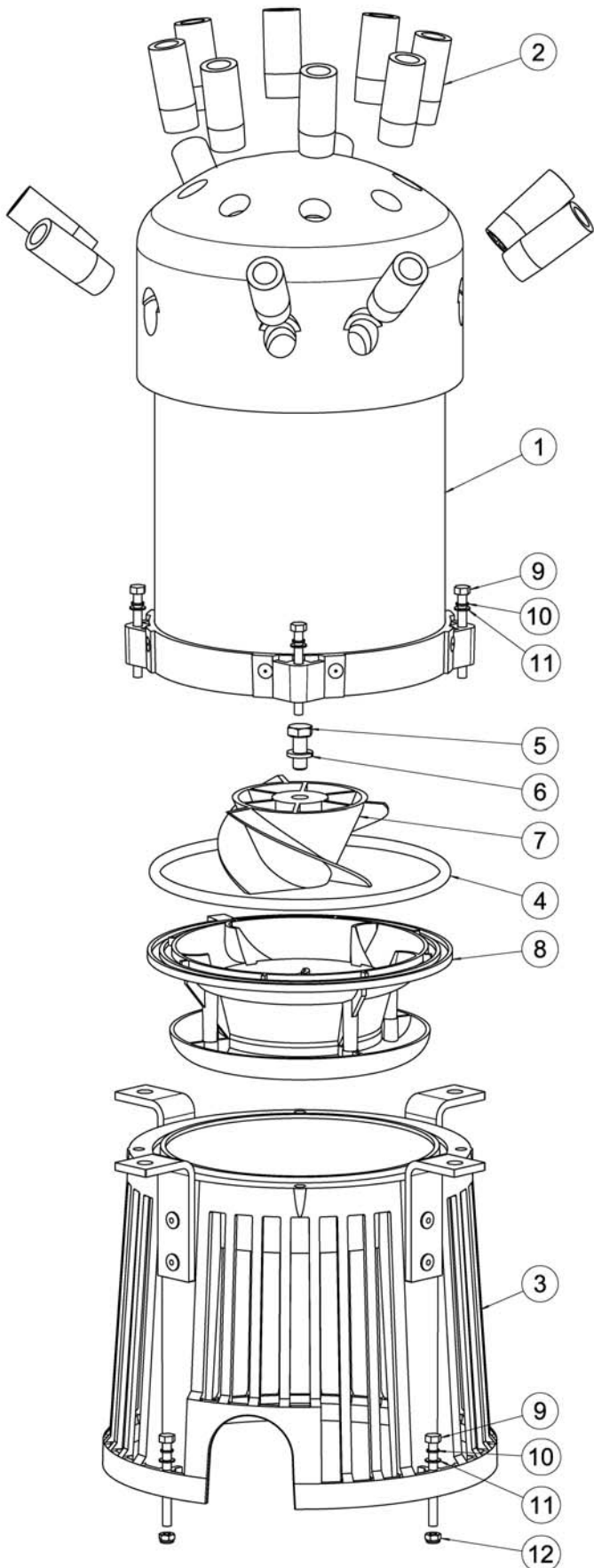

Parts List			
Item	Description	Part Number	Qty
1	Genesis Throat Assembly	10-0073	1
2	Genesis Nozzle	10-0068	16
3	Standoff Strainer Assembly	10-0061	1
4	O-Ring #260	49-0015	1
5	M8x20 S/S Hex Bolt	22-0019	1
6	M8 (5/16'') S/S Split Lock Washer	28-0019	1
7	Decorative Impeller 1HP, 60Hz 2HP, 60Hz 3HP, 60Hz 5HP, 60Hz	50-0010-001 50-0010-002 50-0010-003 50-0010-005	1
8	Lower Pump Chamber Assembly	10-0065	1
10	M5x50 S/S Hex Bolt	24-0013	8
11	M5 S/S Split Lock Washer	28-0017	8
12	M5 S/S Flat Washer	28-0016	8
13	M5 S/S Nylon Locknut	26-0006	4
14	Decorative Impeller Shim (not shown)	40-0099	1,2,3, or 4

Genesis Assembly Instructions

1. Mount the Standoff Strainer Assembly to the power unit using (4) M5x50 S/S Hex Screws, (4) M5 S/S Flat Washers, (4) M5 S/S Split Lock Washers, and (4) M5 S/S Hex Nylon Locknuts. Tighten the screws evenly. **NOTE:** Standoff Strainer Assembly is not part of the Pump Chamber Assembly.
2. Place the Lower Pump Chamber Assembly into the Standoff Strainer Assembly.
3. Slide the Impeller onto the motor shaft. If the Impeller rubs against the inside wall of the Lower Pump Chamber Assembly place 1, 2 or 3 Shims (Item 13) as necessary onto the shaft to raise the Impeller so it no longer rubs. Secure using (1) M8x20 S/S Hex Bolt and (1) M8 S/S Split Lock Washer. Tighten the bolt.
4. Place an O-ring in the groove of the Lower Pump Chamber Assembly.
5. Place the Genesis Throat Assembly onto the Lower Pump Chamber Assembly and secure using (4) M5x50 S/S Hex Screws, (4) M5 S/S Flat Washers, and (4) M5 S/S Split Lock Washers. Tighten the screws evenly in order to properly compress the o-ring. **NOTE:** The Float must be mounted before the Genesis Throat Assembly is installed (See Float Mounting Instructions).
6. Thread a Genesis Nozzle into one of the holes in the Galaxy Diffuser and tighten (**DO NOT OVERTIGHTEN, MAY CAUSE DAMAGE**). Repeat for the remaining fifteen Genesis Nozzles. **NOTE:** Place Teflon tape on the threads of the Genesis Nozzle.

EQUINOX PUMP CHAMBER

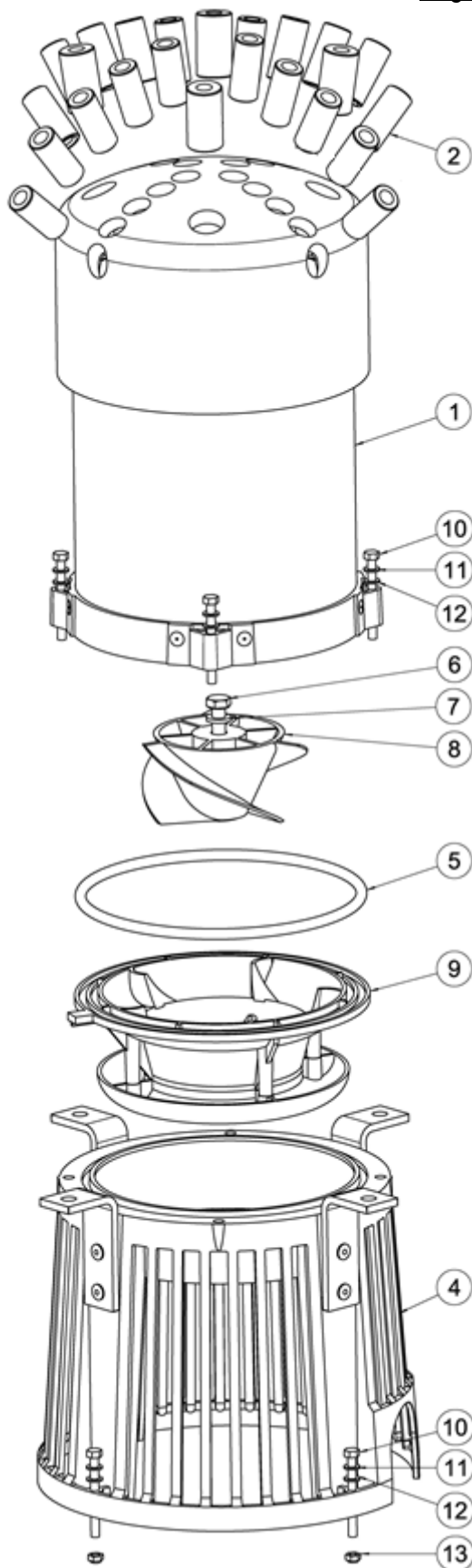

Parts List			
Item	Description	Part Number	Qty
1	Equinox Throat Assembly	10-0008	1
2	1/2" NPT x 1-1/2" Nozzle	41-0023	24
4	Standoff Strainer Assembly	10-0061	1
5	O-Ring #260	49-0015	1
6	M8x20 S/S Hex Bolt	22-0019	1
7	M8 (5/16") S/S Split Lock Washer	28-0019	1
8	Decorative Impeller 1HP, 60Hz 2HP, 60Hz 3HP, 60Hz 5HP, 60Hz	50-0010-001 50-0010-002 50-0010-003 50-0010-005	1
9	Lower Pump Chamber Assembly	10-0065	1
10	M5x50 S/S Hex Bolt	24-0013	8
11	M5 S/S Split Lock Washer	28-0017	8
12	M5 S/S Flat Washer	28-0016	8
13	M5 S/S Nylon Locknut	26-0006	4
14	Decorative Impeller Shim (not shown)	40-0099	1,2,3, or 4

Equinox Assembly Instructions

1. Mount Standoff Strainer Assembly to the power unit using (7) M5x50 S/S Hex Screws, (4) M5 S/S Flat Washers, (4) M5 S/S Split Lock Washers, and (4) M5 S/S Hex Nylon Locknuts. Tighten the screws evenly. NOTE: Standoff Strainer Assembly is not part of the Pump Chamber Assembly.
2. Place the Lower Pump Chamber Assembly into the Standoff Strainer Assembly.
3. Place a shim (Item 14) on the top of the motor shaft prior to installing the impeller onto the motor shaft. If the Impeller rubs against the inside wall of the Lower Pump Chamber Assembly add another shim (do not use more than four (4) shims). Secure impeller using (1) M8x20 S/S Hex Bolt and (1) M8 S/S Split Lock Washer. Tighten the bolt.
4. Place an O-ring in the groove of the Lower Pump Chamber Assembly.
5. Place the Equinox Throat Assembly onto the Lower Pump Chamber Assembly and secure using (4) M5x50 S/S Hex Screws, (4) M5 S/S Flat Washers, and (4) M5 S/S Split Lock Washers. Tighten the screws evenly in order to properly compress the o-ring. NOTE: The Float must be mounted before the Equinox Throat Assembly is installed (See Float Mounting Instructions).
6. If replacing nozzles on the Equinox throat assembly place Teflon tape on the threads of the nozzle and DO NOT OVERTIGHTEN, THE THROAT MAY BE DAMAGED.

OMEGA PUMP CHAMBER

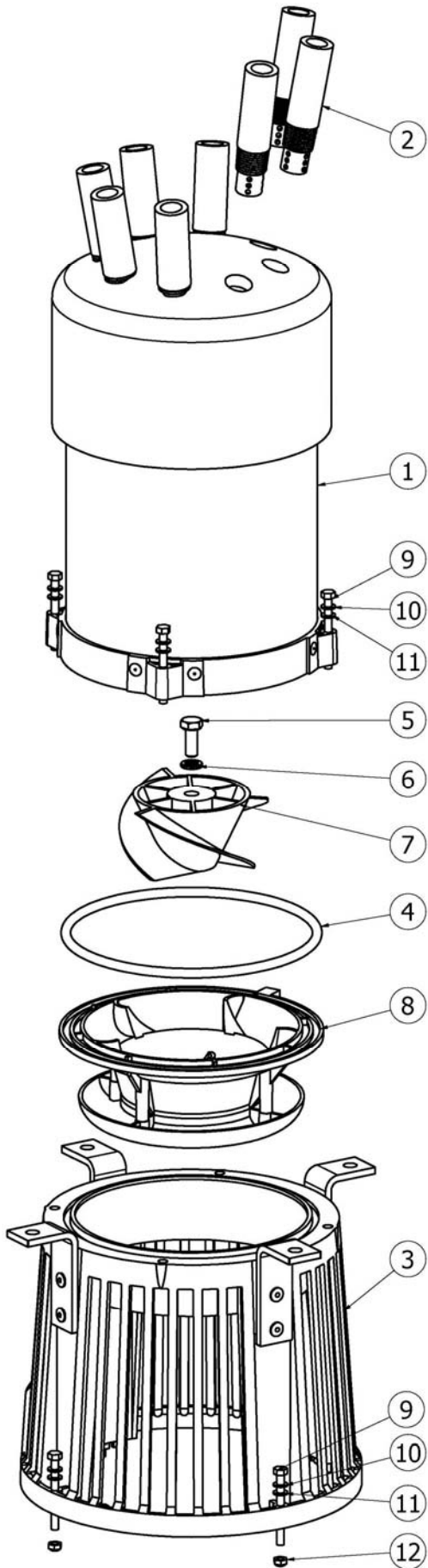

Parts List			
Item	Description	Part Number	Qty
1	Omega Throat Assembly	10-0053	1
2	Omega Nozzle	41-0115	8
3	Standoff Strainer Assembly	10-0061	1
4	O-Ring #260	49-0015	1
5	M8x20 S/S Hex Bolt	22-0019	1
6	M8 (5/16") S/S Split Lock Washer	28-0019	1
7	Decorative Impeller 1HP, 60Hz 2HP, 60Hz 3HP, 60Hz 5HP, 60Hz	50-0010-001 50-0010-002 50-0010-003 50-0010-005	1
8	Lower Pump Chamber Assembly	10-0065	1
9	M5x50 S/S Hex Bolt	24-0013	8
10	M5 S/S Split Lock Washer	28-0017	8
11	M5 S/S Flat Washer	28-0016	8
12	M5 S/S Nylon Locknut	26-0006	4
13	Decorative Impeller Shim (not shown)	40-0099	1,2,3, or 4

Omega Assembly Instructions

1. Mount Standoff Strainer Assembly to the power unit using (7) M5x50 S/S Hex Screws, (4) M5 S/S Flat Washers, (4) M5 S/S Split Lock Washers, and (4) M5 S/S Hex Nylon Locknuts. Tighten the screws evenly. NOTE: Standoff Strainer Assembly is not part of the Pump Chamber Assembly.
2. Place the Lower Pump Chamber Assembly into the Standoff Strainer Assembly.
3. Place a shim (Item 14) on the top of the motor shaft prior to installing the impeller onto the motor shaft. If the Impeller rubs against the inside wall of the Lower Pump Chamber Assembly add another shim (do not use more than four (4) shims). Secure the impeller using (1) M8x20 S/S Hex Bolt and (1) M8 S/S Split Lock Washer. Tighten the bolt.
4. Place an O-ring in the groove of the Lower Pump Chamber Assembly.
5. Place the Omega Throat Assembly onto the Lower Pump Chamber Assembly and secure using (4) M5x50 S/S Hex Screws, (4) M5 S/S Flat Washers, and (4) M5 S/S Split Lock Washers. Tighten the screws evenly in order to properly compress the o-ring. NOTE: The Float must be mounted before the Omega Throat Assembly is installed (See Float Mounting Instructions).
6. If replacing nozzles on the Omega throat assembly place Teflon tape on the threads of the nozzle and DO NOT OVERTIGHTEN, THE THROAT MAY BE DAMAGED.

Limited 5 Year Warranty
Otterbine® Product

WARRANTY: Barebo, Inc 3840 Main Road East, Emmaus Pennsylvania 18049, U.S.A. hereby warrants, subject to the conditions herein below set forth, that should the **OTTERBINE** product prove defective by reason of improper workmanship or materials at any time during the warranty period the Purchaser at retail will be guaranteed that **BAREBO** will repair or replace the said **OTTERBINE** product as may be necessary to restore it to satisfactory operating condition, without any charge for materials or labor necessarily incident to such repair or replacement, provided that:

- a) The enclosed Warranty Registration Card should be mailed to **BAREBO** within fifteen (15) days of the original receipt by the Purchaser at retail in order to avoid delays:
- b) The **OTTERBINE** product must be delivered or shipped, prepaid, in its original container or a container offering an equal degree of protection, to **BAREBO** or a facility authorized by **BAREBO** to render the said repair or replacement services or, if purchased from an authorized **OTTERBINE** dealer, to such dealer;
- c) The **OTTERBINE** product must not have been altered, repaired or serviced by anyone other than **BAREBO**, a service facility authorized by **BAREBO** to render such service, or by an authorized **BAREBO** dealer, and the serial number of the **OTTERBINE** product must not have been removed or altered: and
- d) The **OTTERBINE** product must not have been subjected to lightning strikes and other Acts of God, vandalism, freezing-in, accident, misuse, or abuse, and must have been installed in conformance with applicable electrical codes (including proper electrical protection), and also installed, operated and maintained in accordance with guidelines in the Owner's Manual shipped with the Otterbine product.
- e) The **OTTERBINE** product must be physically inspected on an annual basis to insure the unit, the connector and the power cable are not damaged and are in proper working condition.

No implied warranties of any kind are made by **BAREBO** in connection with this **OTTERBINE** product, and no other warranties, whether expressed or implied, including implied warranties of merchantability and fitness for a particular purpose, shall apply to this **OTTERBINE** product. Should this **OTTERBINE** product prove defective in workmanship or material, the retail Purchaser's sole remedy shall be repair or replacement as is hereinabove expressly provided and, under no circumstances, shall **BAREBO** be liable for any loss, damage or injury, direct or consequential, arising out of the use of, or inability to use, the **OTTERBINE** product, including but not limited to retail Purchaser's cost, loss of profits, goodwill, damages due to loss of product or interruption of service, or personal injuries to Purchaser or any person.

MODEL (circle one): Sunburst Gemini Rocket Phoenix
Tri-Star Saturn Comet Constellation
Genesis Omega Equinox

HORSEPOWER (circle one): 1 2 3 5

VOLTAGE (circle one): 115 230 208-230 380 415 460 575

PHASE (circle one): Single Three HERTZ (circle one): 50 60

CORD GAUGE & LENGTH _____

UNIT SERIAL NUMBER _____

PANEL SERIAL NUMBER _____

OPTIONS _____



Water Works With Otterbine!

**Otterbine/Barebo, Inc.
3840 Main Rd. East
Emmaus, PA. 18049
U.S.A.**

**PHONE: 1-800-AER8TER (237-8837) or (610) 965-6018
FAX: (610) 965-6050
E-mail: aeration@otterbine.com
www.otterbine.com**